

# 2010 Product Guide

**What's new?**



**P1.5, P6 & P8 Pressure Sprayers**



**BPM Motorised Back Pack**



**NK 1000L**



**RANGER Row Crop**



**GRASSLAND**



**MASTER 1500 & 1800L**



**ZEBRA**



**NEPTUN**



**ZATURN**

**Contents**

**HARDI Sprayers .....3**  
 Pressure & Backpack sprayers..... 3  
 Motorised backpack BPM-100..... 4  
 SWIFT compact sprayers..... 4  
 ESTATE Professional & ESTATE Turf ..... 5  
 BIKE PACKS and accessories.....6  
 Professional 12 Volt..... 7  
 ATV Single & tandem axle trailers..... 8  
 PICK-UP Sprayer, WHEELBARROW ..... 9  
 BOSS trailer Turf Sprayer ..... 10  
 BOSS demount Turf Sprayer ..... 11  
 NK & NL 400, 600, 800 Linkage ..... 12  
 NK & NL Linkage options ..... 13  
 NK 1000 Linkage ..... 14  
 GRASSLAND 1200 Trailer ..... 16  
 RANGER GRASSLAND 2200 Trailer ..... 18  
 MASTER Linkage ..... 20  
 MASTER TWIN STREAM Linkage..... 22  
 CAT 3 Linkage..... 24  
 RANGER Row Crop Trailer..... 26  
 RANGER Trailer ..... 28  
 NAVIGATOR Trailer ..... 30  
 COMMANDER, COMMANDER i Trailer ..... 32  
 ALPHA Self-Propelled ..... 34  
 SARITOR Self-Propelled ..... 35  
 ZENIT & ZATURN Vine Mistblower..... 36  
 MERCURY COVAMAX Mistblower ..... 37  
 ZEBRA Mistblower ..... 38  
 NEPTUN Mistblower..... 39  
 ZATURN Mistblower..... 40  
 MERCURY Mistblower ..... 41  
**Pumps, pump repair kits .....42**  
**Operating units & controllers .....43**  
**Granni Pot .....43**  
**Booms, accessories .....44**  
**Nozzles.....45**  
**HARDI Academy.....49**  
**Dealer contacts .....50**

**Contacts**

**CENTRAL (SA, NT)**



**Regional Manager**  
Trevor Pahl  
0428 815 150  
tgp@hardi-aus.com



**Territory Manager**  
Brad King  
0427 445 367  
bk@hardi-aus.com



**Regional Manager**  
Peter Vella  
0417 181 725  
piv@hardi-aus.com



**Territory Manager**  
Dave Rogers  
0427 921 522  
dpr@hardi-aus.com

**HARDI Australia Pty Ltd**  
 ABN 74 076 150 617 ACN 076 150 617  
 534-538 Cross Keys Road,  
 Cavan, SA 5094  
**P:** (08) 8343 9999  
**F:** (08) 8343 9960  
**E:** info@hardi-aus.com  
**W:** www.hardi.com.au

**Perth**  
 8 Glassford Road,  
 Kewdale, WA 6105  
**P:** (08) 9353 2088  
**F:** (08) 9353 6811

**Brisbane**  
 21 Machinery Street,  
 Darra, QLD 4077  
**P:** (07) 3375 3544  
**F:** (07) 3279 1292

**NORTHERN (Nth NSW, QLD)**



**Operations Manager**  
Linden Forbes  
0488 424 204  
lf@hardi-aus.com



**Territory Manager**  
Andrew Uphill  
0429 192 770  
abu@hardi-aus.com



**Territory Manager**  
Paul Tuohy  
0418 465 130  
ptj@hardi-aus.com

**SOUTHERN (Sthn NSW, Vic & Tas)**



**Regional Manager**  
Graham Wilkinson  
0419 326 902  
gw@hardi-aus.com



**Territory Manager**  
David Soderstrom  
0419 321 693  
djs@hardi-aus.com



**Territory Manager**  
Roger Cooper  
0428 861 290  
rogerc@hardi-aus.com



**Territory Manager**  
Mark Eskridge  
0417 582 153  
mre@hardi-aus.com

**FCI** Freight calculation included

**i** More information found on website

**Disclaimer**

All prices listed are GST inclusive, and are recommended prices excluding insurance, pre-delivery, dealer delivery and installation costs. Freight is excluded except where indicated **FCI** (Freight calculation included). Prices are effective from the 1<sup>st</sup> March 2010. Some configured sprayer prices listed are examples and should be used as a guide only. HARDI Australia reserves the right to change specifications and recommended prices without notice. Photos are for illustration purposes only and may show accessories and options not included in the price.

**HARDI Guarantee**

To keep you spraying easier, faster and more efficiently... HARDI products are built to the highest standard for long life and hassle-free service. Our operator training, warranty and service support ensures you get the most from your investment.

**Pressure & Backpack**

**Hand operated sprayers built to last**

Ideal for home gardener, hobby farmer, small business and pest control operator. For the application of weed and pest control products, cleaning solutions and disinfectants.

Built from high quality material for long life, with readily available parts for easy service.

Pressure sprayer's use ergonomic plunger pump to pressurise the container and a trigger valve to control intermittent or continuous spraying.

Backpack sprayers uses a lever operated piston pump with compression chamber for low pumping frequency and is capable of high operating pressure. Comfortable ergonomic adjustable shoulder straps and waist belt.

4 nozzle boom  
**\$ 39.59**

**FCI** P1.5 84640300  
**\$ 13.20**

**FCI** P6 84640100  
**\$ 100.10**

**FCI** P8 84640200  
**\$ 108.90**

**FCI** BP15 846258  
**\$ 187.79**



**P8 pressure sprayer**

Plunger pump operation pressurises the container for spraying



**P1.5 pressure sprayer**

Plunger pump operation pressurises the container for spraying



**Telescopic lances**

A compact extension for tall targets. Available from 0.5 m to 2.0 m.



**Spray shields**

To avoid spray drift. 0.4 m and 0.2 m.

Accessories	Part No	RRP
0.37m Lance	72033100	\$16.50
0.5m Lance	72032900	\$22.00
1.0m Lance	730441	\$30.80
0.5 -1.0m Telescopic Lance	755755	\$24.20
0.75 -1.5m Telescopic Lance	755741	\$35.20
1.0 - 2.0m Telescopic Lance	755742	\$46.20
Constant flow valve	741651	\$40.89
Double nozzle holder, inc nozzle	755750	\$39.86
2 nozzle boom	755746	\$20.90
3 nozzle boom	755747	\$26.40
4 nozzle boom	755748	\$38.50
Fan shield, including nozzles	741647	\$24.99
Cone shield, including nozzle	741721	\$24.99
Adjustable nozzle kit (18mm)	755835	\$13.75



**Adjustable nozzles**

Spray angle, reach and spray quality can quickly be changed. 0.88 to 1.65 L/min.



**Double nozzle holder**

For higher volumes of fine spray.



## BPM-100 mistblower

Coverage and control

## HANDI Sprayers

**New!**

The Back Pack Motorised 100 mistblower with centrifugal fan is designed for spraying against pests and diseases in market gardens, orchards, vineyards and all types of plantations as well applying disinfectants to buildings.

The air shear nozzle system produces a fine mist (200 to 500 micron) and spraying with volumes as low as 30 to 60 L/ha is possible.

- Padded back support for comfort
- Wide easy-to-adjust carry straps
- Centre of gravity close to the operator
- Electronic ignition
- Large capacity fuel tank allowing 1½ hours of spraying
- Liquid preset valve from 1.2 to 2.3 L/min
- Multi-function control handle

## ESTATE

Making light work of weed free lawn

## HANDI Sprayers



**FCI** ESTATE Professional  
809056  
\$ 2,096.89

**FCI** BPM-100 backpack mistblower with 5 HP motor  
16 litre      7.6 L/m      84640000      \$1,208.90



## SWIFT



**FCI** 100 litre,  
84600404  
\$ 678.15

### SWIFT features:

- 12-Volt 25, 50 and 100 litre compact sprayers
- Lance or 60S spraygun with adjustable nozzle
- Flojet diaphragm pump & fuse protection
- 6 metre hose
- Internal suction filter on Lance

### **FCI** SWIFT with lance

Model	Open flow	Part No	RRP
25 litre	3.8 L/m	846264	\$417.87
50 litre	3.8 L/m	846265	\$494.54
100 litre	3.8 L/m	846266	\$613.58
50 litre	7.6 L/m	84600204	\$557.87
100 litre	7.6 L/m	84600404	\$678.15

### **FCI** SWIFT with 60S Gun

50 litre	7.6 L/m	84600704	\$698.18
100 litre	7.6 L/m	84600804	\$818.46

**Outstanding value and versatility** - Ideally suited to meet the spraying needs of the lifestyle farmer, garden lover, estate owner, nursery professional, ground maintenance, municipal and industrial caretaker.

For spot spraying weeds, controlling pest and disease on fruit trees or ornamental plants, applying liquid fertilizers and can be used for industrial applications such as cleaners and disinfectants.



**FCI** 25 litre  
846264  
\$ 417.87

**FCI** 50 litre  
846265  
\$ 499.54

**FCI** 100 litre  
84600804  
\$ 818.46

## ESTATE Professional

A heavy duty 120 litre estate sprayer for the serious turf care professional. It comes with wide flotation tyres for low compaction, 2 metre boom and adjustable lance with 6 metre hose. The tank has a graduated level indicator and there is a deep sump for draining

- 2 metre boom on Estate Professional
- Lance with adjustable nozzle and 6 metre hose
- Polyethylene graduated tank
- Internal suction filter
- Flojet diaphragm pump and fuse protection

### **FCI** ESTATE Professional

120 litre, 7.6 L/m      809056      \$2,096.89

### Optional

60S spray gun, hose & hose tail      70026804      \$207.91

## ESTATE Professional



**FCI** ESTATE Turf  
84604004  
\$ 1,182.50

## ESTATE Turf

A well balanced 120 litre sprayer designed to be towed behind ride on lawn mowers and comes complete with wide tyres, pump, filter, pressure regulation and gauge. A distribution valve controls flow to the spray lance and 3 nozzle boom.

- 1.5 metre boom on Estate Turf
- Lance with adjustable nozzle and 6 metre hose
- Internal suction filter
- Flojet diaphragm pump and fuse protection

### **FCI** ESTATE Turf

	Part No	RRP
120 litre, 7.6L/m control, lance	84604004	\$1,182.50
120 litre, 7.6 L/m control, 60S gun	84604104	\$1,383.38

**BIKE Packs**  
Proven performance

**HARDI Sprayers**

**12-Volt Professional**  
Designed for performance

**HARDI Sprayers**



**FCI** 75 litre 84602504  
\$758.22 +  
Pressure control  
84100004 **\$186.71**  
= **\$944.93**



**FCI** 250 litre  
84602104  
60S Gun, 20 m  
hose reel & hose  
**\$ 1,404.82**

HARDI BIKE sprayers are made to fit most quad bikes, allowing the bike to be turned into a mobile sprayer with capacities of 50 or 75 litres. The bike packs are designed to provide a low centre of gravity and the tank shape has smooth contours.

The bike packs include 6m hose with 700m lance and adjustable nozzle for fine to coarse spray or 60S Spray Gun for more heavy duty application

The BIKE PACKS are ideally suited for large and dispersed areas, for spot spraying and for spraying hard to reach areas. Small 2, 3, or 4 metre wide spray booms when attached provide a high work rate when small fields need to be sprayed. Features:

- Lance or 60S spray gun with adjustable nozzle and 6 metre hose
- Internal suction filter on the lance
- Flojet diaphragm pump with fuse
- Ratchet tie-down strap

Options:

- Pressure regulation and gauge
- 60S spray gun
- 3-way distribution valve



**FCI** 75 litre  
84601004  
**\$ 882.39**



**FCI** 100 litre  
84601204  
**\$ 920.50**



**FCI** 100 litre 60S, 6m hose,  
pressure regulation  
84601304  
**\$ 1,105.52**

**FCI HARDI BIKE Sprayer, lance, demand pump**

Model	Open flow	Part No	RRP
50 litre	7.6 L/m	84600004	\$622.44
75 litre	3.8 L/m	846267	\$677.51
75 litre	7.6 L/m	84602504	\$758.22

**FCI HARDI BIKE Sprayer, 60S Gun, demand pump**

50 litre	7.6 L/m	84600104	\$762.76
75 litre	7.6 L/m	84601004	\$882.39

**FCI HARDI BIKE Sprayer, 60S Gun, Control 3, pressure reg & gauge**

75 litre	7.6 L/m	84602404	\$1,246.23
----------	---------	----------	------------

**FCI HARDI BIKE Boom**

1.5 metre rigid	5908100	\$240.22
2 metre rigid	5908102	\$286.90
3 metre breakaway	5908104	\$754.30
4 metre breakaway	5908105	\$744.61

**FCI 12-Volt Sprayer Accessories**

Pressure control w/- gauge	84100004	\$186.71
60S spray gun	843196	\$170.78



**FCI** Optional small 50 litre  
front tank  
84600004  
**\$ 622.44**

843196 -  
**\$ 170.78**

3 metre breakaway  
5908104  
**\$ 754.30**

84100004 - **\$ 186.71**

Professional sprayers available with 100, 250 & 300 litre volumes has a proven high capacity pump for reliable long service and increased agitation for good mixing. They come with 60S handgun, on-off switch with fuse to safeguard the pump from short circuits and optional hose reel for the 250 litre model. The PROFESSIONAL sprayers have optional pressure regulation and are ideally suited to higher capacity spraying. Features:

- 60S spray gun and 6 metre hose
- External suction filter
- Flojet diaphragm pump and fuse protection
- Optional pressure regulation, gauge and 3-way boom distribution for application precision

**FCI Professional sprayers, demand dump**

	Part No	RRP
100 litre, 7.6 L/m	84601204	\$920.50
250 litre, 7.6 L/m	84600504	\$1,111.33
250 litre, hose reel & hose 7.6 L/m	84602104	\$1,404.82
300 litre, 7.6 L/m	84600604	\$1,328.96

**FCI Professional sprayers, pressure regulation control**

100 litre, 7.6 L/m	84601304	\$1,105.52
250 litre, 7.6 L/m	84601504	\$1,291.94
250 litre, hose reel & hose, 7.6 L/m	84602204	\$1,585.44
250 litre, hose reel & hose, 13.6 L/m	84602304	\$1,653.17
300 litre, 7.6 L/m	84601704	\$1,517.71

ATV Trailers  
Capacity and flotation



FCI 300 litre  
5911676  
\$ 3,383.79

HANDI Sprayers

Power Sprayers  
Motorised versatility



FCI 200 litre,  
50 m hose reel,  
hose & 60S gun

HANDI Sprayers

ATV 12-Volt Trailers

200, 300 & 400 litre heavy duty single or tandem axle ATV trailed sprayers with high flotation tyres offers serious capacity for small farming operations. ATV sprayers are an excellent alternative to small three point linkage where capacity is required but towing is the preferred option. A standard 50 mm trailer coupling draw bar provides a smooth ride and easy connection to ATV quad bikes, small tractors and utility's.

With a choice of 3 or 4m boom on the 200 & 300 litre trailer and 6 or 8m boom on the 400 these ATV sprayers covers the ground fast and efficiently. The 400 litre trailer is standard with shock absorbers dampened drawbar to minimise shock transfer.

All models are great for spot spraying with 6 metres of hose and a 60S spray gun. Features:

- External suction filter
- Flojet diaphragm pump with fuse protection
- Pressure regulation, gauge and 3-way boom distribution
- Heavy duty chassis with flotation tyres



FCI 300 litre  
5911676  
\$ 3,383.79



FCI 400 litre  
5911684  
\$ 5,361.14

FCI ATV trailed 3 way distribution kit sprayers, single axle

	Part No	RRP
200 L, 3m ATV boom	5911670	\$3,056.43
200 L, 4m ATV boom	5911671	\$3,158.02
300 L, 3m ATV boom	5911675	\$3,282.19
300 L, 4m ATV boom	5911676	\$3,383.79

FCI ATV trailed 3 way distribution kit sprayers, tandem axle

400L 6m SB boom, Flojet	5911684	\$5,361.14
400L 8m SB boom, Flojet	5911685	\$5,995.35

Optional

Trapeze for SB boom	727571	\$825.00
20m hose reel, hose & 60S gun	5904101	\$531.30
TFL - single side foam marker	5904212	\$1,269.40

PICK-UP Skid Mount

Slide on versatility for when the applications call for higher volumes and variable pressure control the versatile range of HARDI motorised power sprayers deliver excellent spray coverage to get the big jobs done quickly. The cast iron HARDI diaphragm pump at the heart of every HARDI motorised sprayer offers high performance and low maintenance. Featuring:

- Heavy duty integrated tank and chassis

FCI Model, pump, capacity	Part No	RRP
200 litre, 4 hp, 503, 16 L/m	5903201	\$3,602.87
300 litre, 4 hp, 603, 31 L/m	5903204	\$4,063.81
400 litre, 4 hp, 603, 31 L/m	5903205	\$4,375.72
600 litre, 4 hp, 603, 31 L/m	5903206	\$4,489.13

Optional

Solenoid Control with pressure reg	5902775	\$1,405.80
50m hose reel, swivel bracket & 60S gun	5904116	\$1,250.70
TFL 24 litre - double-sided foam marker	5904210	\$1,463.00
15 litre fresh water tank	722072	\$158.50
6 m SB Boom	817047	\$1,347.34
8 m SB Boom	817062	\$1,772.55
10 m SB Boom	817084	\$2,093.98
Boom Mount for SB/ATV Booms	5915448	\$703.64
Trapeze suspension kit for SB boom	727571	\$825.00

WHEELBARROW

Mobile motorised versatile

- 120 litre integrated chassis and tank design
- Direct-coupled pump engine
- Large pneumatic wheel

FCI Model	Tyres	Part No	RRP
4 hp, 16 L/m	4.00/3.50-R12	80900404	\$3,576.11
4 hp, 31 L/m	18/9.5-R8	80900504	\$3,802.94

Optional

50m hose reel, hose & 60S gun	5904110	\$1,237.50
-------------------------------	---------	------------



120 litre,  
31L/m, hose  
reel, hose &  
60S spray gun  
\$ 4,718.78

# BOSS Trailer

Outstanding sports turf application

Turf



# BOSS Demount

Purpose built turf application

Turf



Enjoyable leisure areas are a reflection of good management and the correct use of the right equipment. The BOSS range is simple and easy to use and ideally suited to the application required in turf care.

BOSS 400 & 600L sprayers with 6, 8 or 10m booms, triplet nozzles and manual or electric valve control optimises application precision and easy to use. The chemical resistant & UV stabilised tank has a graduated level indicator, internal suction filter and deep sump for drainage.

The HARDI diaphragm pump with 99L/m output is self priming and can be run dry without harm. Three section distribution with pressure equalisation is standard, with an extra valve for spraygun. Features:

- BK180 control
- Low draw bar
- 23 x 10.5-1 tyres
- PTO shaft
- Triplet saddles
- 3 way distribution kit
- 15L clean water tank
- safety locker calibration
- with 1203 pump at 99 L/m

Model	Part No	RRP
400, 6m SB	80304802	\$10,044.24
400, 8m SB	80304902	\$10,636.03
400, 10m SB	80305002	\$11,504.88
600, 6m SB	80305102	\$10,522.74
600, 8m SB	80305202	\$11,114.54
600, 10m SB	80305302	\$11,983.38

Optional		
Reel, 30 m hose 3/8", & 60S Spraygun		\$467.50
End nozzle kit	5908200	\$92.40
Hydro-motor drive for demount	83608002	\$1,611.50
Foam marker TFL	818117	\$1,463.00
HC2500 with flow sensor	72258600	\$3,273.60
In lieu pump 1203-1000 (108 L/min; 15 bar)	821629	\$225.50



The BOSS demount sprayer configuration is very user friendly and fits most utility vehicles. The low profile tanks are available in 400 & 600 litre capacities. The four support legs are used for mounting and demounting the sprayer. Features:

- Retractable removable legs
- EVC control
- 25L ChemFiller
- PTO shaft, triplet saddles
- 3 way distribution
- 5L clean water tank
- Safety locker and calibration kit
- 1203 at 99 L/m



Model	Part No	RRP
400, 6m SB	80303602	\$8,944.24
400, 8m SB	80303702	\$9,536.04
400, 10m SB	80303802	\$10,404.88
600, 6m SB	80303902	\$9,422.74
600, 8m SB	80304002	\$10,014.54
600, 10m SB	80304102	\$10,883.38

### Demount Kits

Kit for TORO Workman	731387	\$407.00
Kit for Jacobsen utility vehicle	728592	\$191.40
Kit for Cushman utility vehicle	728593	\$179.30
Kit for JD Gator	70043002	\$418.00

### Optional

Reel, 30 m hose 3/8", & 60S Spraygun		\$467.50
End nozzle kit	5908200	\$92.40
Hydro-motor drive for demount	83608002	\$1,611.50
Foam marker TFL	818117	\$1,463.00
HC2500 with flow sensor	72258600	\$3,273.60
In lieu pump 1203-1000 (108 L/min; 15 bar)	821629	\$225.50



# NL & NK

## Leading choice in linkage

### Proven user friendly design

400, 600, 800 litre capacity, 6, 8, 10 & 12m boom



### Nozzles for optimum distribution

F .03 at 3 Bar



65 L/ha at 15 kph

LowDrift .03 at 3 Bar



65 L/ha at 15 kph

MINIDRIFT .03 at 3 Bar



65 L/ha at 15 kph

The NL and NK linkage range are easy, fast and efficient sprayers ideal for small to medium pastural and cropping programs.

NL has M70 control with pressure regulation gauge while the NK has BK-180 proportional rate control to deliver a more precise application at variable forward speeds. Features:

- Integrated tank and chassis design
- Blow moulded tank strength and durability
- No tank corners or sediment traps
- Safe tank drain operation
- Self priming diaphragm pump, can run dry without harm
- Grease pump crankcase...no oil
- Snap fit F series nozzles standard, colour coded for size
- High quality powder coating with zinc phosphate pre-treatment

#### NL configuration:

- M70 pressure regulation and bypass control
- 3 stage filtration

#### NK configuration:

- HARDIMatic - correct application rate at variable forward speeds
- Pressure agitation of tank contents
- Constant nozzle pressure when turning boom sections off
- 4 stage filtration

FCI NL / NK with pump & capacity	Op Unit	RRP
NL 300, 6m SB, 503, 16 L/m	M70	\$3,734.10
NK 300, 6m SB, 603, 31 L/m	BK-180	\$4,284.10
NL 400, 6m SB, 603, 31 L/m	M70	\$4,077.30
NK 400, 8m SB, 603, 31 L/m	BK-180	\$4,834.69
NL 600, 8m SB, 603, 31 L/m	M70	\$4,933.69
NK 600, 8m SB, 603, 31 L/m	BK-180	\$5,346.20
NL 800, 10m SB, 1203, 99 L/m	M70	\$6,622.79
NK 800, 10m SB, 1203, 99 L/m	BK180	\$7,035.29
NK 800, 10m SB, 1203, 99 L/m	SC-3	\$8,028.59

#### Optional

TFL - single sided, switch box	\$1,263.90
TFL - double sided foam marker	\$1,463.00
15 litre clean water tank	\$198.00
Manual end nozzle assembly	\$92.40
Trapeze suspension for SB boom	\$822.80
30m hose reel, hose and 60S handgun	\$467.50
JetChester boomless nozzle	\$348.70
SC-3 electric pressure & section control	\$1,695.10
SC-3 with HC2500 controller	\$4,239.64



#### JetChester boomless nozzle

Broadcast boomless nozzle assembly, simply attaches to the linkage frame

#### NL-400-503-M70 with JetChester \$3118.50

# NL & NK

## Leading choice in linkage



NL & NK Under Vine & Tree herbicide boom are available in single or double sided heavy duty steel configuration. Feature:

- Breakaway, nozzle protection and width adjustment
- Two flat fan nozzles
- One off centre adjustable end nozzle

	Part No	RRP
Left side vine boom, no bracket	83317404	\$565.83
Right side vine boom, no bracket	83317504	\$565.83
Left side tree boom, no bracket	83317704	\$604.54
Right side tree boom, no bracket	83317604	\$604.54
Mounting bracket kit	83317804	\$87.81
Centre spray bar, 4 nozzles	83317904	\$262.99

**Hose reels & mounting.** For spot spraying a 50 or 100 m hose reel and hand gun combination makes an ideal addition to the NL/NK sprayer.

50m hose, reel & 60S kit	5904130	\$806.38
50m nylon hose, reel & 60S kit	5904131	\$909.58
100m hose, reel, & 60S kit	5904132	\$1,102.80
100m nylon hose, reel & 60S kit	5904133	\$1,309.23
Angle bracket for single reel	834764	\$86.86
Single side reel bracket	818801	\$282.35
Double side reel mount bracket	818812	\$362.04

**Hydraulic vertical wing folding kit.** Simple vertical wing fold for growers who want to be able to spray with the left or right wings folded. Quick and convenient for folding and turning on headlands

- Double acting left and right hydraulic cylinders
- Remote control valve for left, right or both
- Suitable for 6 and 8 m SB booms only

Hydraulic centre in lieu standard SB centre	5908130	\$2,757.32
Hydraulic wing fold kit, complete	817928	\$2,892.93

#### Hydraulic boom height control with trapeze suspension

Spraying different crop heights - one single acting two stage hydraulic cylinder

Hydraulic boom lift for SB boom	831272	\$2,070.93
---------------------------------	--------	------------



# NK-1000

## Increasing your capacity

1000 litre capacity, 6, 8, 10 & 12m booms

Leading choice in

**New!**



### Nozzles for optimum distribution

F .03 at 3 Bar  
65 L/ha at 15 kph



LowDrift .03 at 3 Bar  
65 L/ha at 15 kph



MINIDRIFT .03 at 3 Bar  
65 L/ha at 15 kph



#### HYS boom option

Match the increased tank capacity with a 12m HYS boom with hydraulic fold.

The renowned NK linkage sprayer range that has provided the versatility required for small to medium pastoral and cropping programs, has just become even more versatile with the introduction of the new 1000L tank!

The blow molded tank is superior in strength and durability, without corners eliminating sediment traps.

Pump, hopper, and boom options have also been increased in capacity for the new tank size...

Comes standard with a quick hitch to make coupling up easier and boom options 6, 8, 10, 12m manual fold and 12m hydraulic fold.

Features:

- Integrated tank and chassis design
- Tank content agitation
- No tank corners or sediment traps
- Blow moulded tank strength and durability
- Self priming diaphragm pump can run dry without harm
- Grease pump crankcase...no oil
- Snap fit quick release nozzles, colour coded for size
- 3 stage filtration
- Colour coded nozzle sizing
- High quality powder coating with zinc phosphate pre-treatment

FCI Tank, boom, pump & capacity	Op Unit	RRP
1000, 10m SB, 1203, 99 L/m	BK-180	\$9,224.29
1000, 12m MB, 1303, 114 L/m	SC-3	\$13,929.74
1000, 12m Hys, 1303, 114 L/m	EVC-3	\$19,899.00

#### Optional

Turbo Filler 25 litre	\$2,619.10
TFL - single sided, switch box	\$1,263.90
TFL - double sided foam marker	\$1,463.00
15 litre clean water tank	\$198.00
80 litre rinse tank & tank rinse nozzle	\$869.00
Manual end nozzle assembly	\$92.40
Electric end nozzle assembly	\$408.10
SC-3 pressure & section control - add in lieu of BK	\$1,695.10
SC-3 with HC2500 controller - add in lieu of BK	\$4,239.64
30m hose reel, hose & 60S handgun	\$467.50
Trapeze suspension for SB boom	\$822.80
Self Cleaning Filter (pump 1202 or 1303 only)	\$299.43
Hi mount transport bracket	\$306.90



#### 363 Pump option

170L/min positive displacement diaphragm pumps can run dry without harm.



#### BK180 Control

Proportional rate control, pressure agitation and boom section control with optional electric cab control.



#### TurboFiller & TurboDeflector

Optional high capacity hopper for fast, safe mixing and transfer of crop materials.



#### Hose reel & mounting brackets

For spot spraying tasks, with 30 of hose and 60S gun.



#### RinseTank

Optional 80L rinse tank is integrated into the chassis and tank design.



#### 15L clean water tank

Optional 15L of clean water on hand for personal hygiene.



#### SC-3 Control

Optional electric proportional rate control, pressure agitation and boom section control from the cab.



#### HARDI Premium Nozzles

Colour coded snap-fit quick-release HARDI nozzles are available in Flat Fan, LowDrift, MINIDRIFT, QUINTASTREAM



# GRASSLAND

Easy pasture renovation and small crop spraying

1000 and 1200L capacity, 6, 8, 10 & 12m boom

Class Leading Sprayer

New!



The GRASSLANDS 1200 litre sprayers makes light work of pasture renovation and small crop spraying.

Trailer suspension and optional air bag boom suspension provides outstanding boom ride and maximises application efficiency.

The GRASSLANDS is a completely integrated design with a low centre of gravity, 48cm crop clearance when fitted with 12.4 x 24 lug tires and 1.8 m track width. The track width on standard 10R x 15 tires is 1.65 m.

The tank profile provides excellent weight distribution and is designed for effective agitation. The 120L rinse tank allows quick, easy in-field clean out

There is a choice of 6, 8, 10 & 12m boom widths with optional air bag suspension, boom inertia trapeze and hydraulic boom height control.

The fluid system is easy to operate with a colour coded SmartValve. Electric pressure regulation and boom section valves are operated from the tractor seat with the SprayBox remote control.

Optional HC2500 controller provides precise application regardless of forward speed.

Features:

- Single axle with suspension
- Standard 10R x 15 & optional 12.4 x 24 tires
- Diaphragm pump
- Electric pressure & solenoid section control
- Double sided foam marker
- Optional Trapeze & air-bag suspension (std on 12 m boom)
- Optional air-bag suspension

*Price examples only. Ask your dealer for further configurations*

1200, 6m SB boom, 1203 pump, 99 L/min, SC/3 control	5902100	\$16,318.50
1200, 10m SB boom, 1203 pump, 99 L/min, SC/3 control	5902100	\$17,381.00
1200, 12m MB boom, 1203 pump, 99 L/Min, SC/3 control	5902131	\$19,716.55



**Integrated design**

A robust integrated design with a low centre of gravity which is logical and easy to use.

**Flush tank**

Standard 120 litre rinse tank provides fast easy in field boom flush.

**Trailer suspension**

Standard leaf spring suspension provides a smooth ride for the trailer and boom.

**High flotation tyres**

Optional 12.4 24 lug tires are ideal for wet conditions and reducing soil compaction.



**Pump**

The fluid system is driven by robust grease-lubricated cast iron diaphragm pump.



**Manifold valve**

Easy to operate SmartValve manifold fluid system.



**Hose reel**

Optional hose reel can be swung out of the way to access the platform.



**SB boom**

6, 8, & 10m SB boom choice with manual height adjustment.



**MB boom**

12 m MB boom option with manual height adjustment air bag boom suspension and trapeze.



**Boom gantry**

Optional hydraulic lift boom gantry for on-the-go boom height control.



**Foam marker**

24 litre TFL double sided foam marker.



**Foam Marker blobber**

Drops small blobs of foam in the field to follow on the next lap.



# RANGER Grassland

## Effortless hydraulic boom fold & height control

2200L capacity, 12, 15, 16m boom

## Class Leading Sprayers



The 2200 litre RANGER Grassland sprayer has surprising spraying performance and makes light work of pasture renovation and small crop spraying. Outstanding boom ride maximises application efficiency and productivity...never has spraying been so clean, effortless and trouble-free.

A completely integrated design with a low centre of gravity, 60cm of crop clearance, 1.56 to 2.34m track width adjustment and paralift boom height control to 1.75m.

The tank design provides excellent weight distribution and is designed for effective agitation.

A fully hydraulic FALCON boom in 12, 15 or 16 metre widths have trapeze inertia control and coil spring suspension.

The fluid system is easy to operate with colour coded manifold valves. Electric pressure regulation and boom section valves are operated from the tractor seat with the SprayBox remote control.

Optional HC2500 controller provides precise application regardless of forward speed.

Options such as the 250L rinse tank allows quick, easy in-field clean out, while a ChemFiller enables fast and safe transfer of crop protection products.

### Features:

- 2200 litre capacity, 12 to 16m FALCON booms
- Lowest centre of gravity in its class
- Strong integration of chassis, axle and paralift towers
- 60cm under-axle crop clearance
- 1.56 to 2.32m track width adjustment
- 0.5 to 1.75m paralift boom height control
- Manifold valve fluid control, easy filling and cleaning
- Optional 250L flush tank
- Self priming diaphragm pump, can run dry without damage
- High capacity chemical transfer with optional ChemFiller

**FCI** Price examples only. Ask your dealer for further configurations

2200, 12m Falcon boom, EVC-3, 1203 pump 99L/m	80300104	\$30,793.40
2200, 15m Falcon boom, EVC-3, 1203 pump 99L/m	80300204	\$32,947.31
2200, 16m Falcon boom, EVC-3, 1203 pump 99L/m	80300304	\$33,735.90

### Pump

The fluid system is driven by robust grease-lubricated cast iron diaphragm pump.

### Control valves

Standard electric pressure, on/off and section control is conveniently located.

### ChemFiller

Optional high capacity hopper for fast, safe mixing and transfer of crop materials.

### Foam Marker

Optional 25 litre TFL double sided foam marker.



### Cab control

Standard SprayBox control with optional HC 2500 rate controller.



### Filling Filter

Optional high capacity filling filter for fast clean water transfer to the main tank.



### RinseTank

Optional 250L rinse tank is mounted over the axle to optimise weight distribution.



### In-Line filter

Optional easy service In-Line filters on the boom to eliminate the need for nozzle filters.

**New!**

# MASTER

**Lifting your capacity & boom flexibility**

800, 1000, 1200, 1500, 1800L capacity, & 12 to 24m boom options

Leading choice in linkage



**FlexForce boom**

## Nozzles for optimum distribution

F .03 at 3 Bar  
65 L/ha at 15 kph



LowDrift .03 at 3 Bar  
65 L/ha at 15 kph



MINIDRIFT .03 at 3 Bar  
65 L/ha at 15 kph



**HYS boom**



**FlexForce boom**

MASTER with tank size 800 to 1800 litre the MASTER sprayers deliver capacity with excellent spraying performance ideal for small cropping and horticultural spraying. Outstanding boom ride maximises application efficiency and productivity...never has spraying been so clean, effortless and trouble-free.

The MASTER is a completely integrated design allowing the weight to be carried close to the tractor and with a low centre of gravity.

The quick hitch integrated into the chassis ensures easy and safe attachment to the tractor.

A range of boom options from 12 to 24metre means there is a boom for every situation and application need. Boom height is control from the tractor with a 2 stage hydraulic boom lift.

The fluid system is easy to operate with colour coded manifold valves. Electric pressure regulation and boom section valves are operated from the tractor seat with the SprayBox remote control.

Optional HC5500 controller provides precise application regardless of forward speed.

FCI Tank	Boom	Fold	Control	Pump	L/m	RRP
800	12MB	Man.	EVC/5	1303	114	\$20,022.53
1000	12MB	Man.	EVC/5	1303	114	\$21,842.37
1000	12HYS	Hyd	EVC/3	1303	114	\$27,065.60
1000	15 FlexForce	Y-Hyd	EVC/5	363	194	\$39,378.11
1200	18 FlexForce	Hyd	EVC/5	363	194	\$41,139.23
1500	21FlexForce	Hyd	EVC/5	363	194	\$45,992.56
1800	21FlexForce	Hyd	EVC/5	363	194	\$48,907.15
1800	24PRO/VPZ	Y-Hyd	EVC/6	363	194	\$52,180.33

Optional	Price
25 Ltr Chemical Filler with rinse nozzle	\$2,179.11
15 Ltr Clean Water Tank	\$226.35
1 x 80 litre rinse/flush tank, & rinse nozzle	\$450.64
HC5500 Controller	\$3,333.48
Air bag suspension for MB boom	\$1,292.20

*Price examples only. Ask your dealer for further configurations*



**Controller**

Optional HC5500 compact rate controller is GPS compatible.



**TurboFiller with TurboDeflector**

Optional high capacity hopper for fast, safe mixing and transfer of crop materials.



**Manifold fluid system**

Easily located fluid direction control, easy to use, maintain and expandable.



**Tank**

Easy access, high-impact UV resistant polyethylene tank with deep sump to ensure complete emptying.

# MASTER TWIN Stream

## TWIN Stream increases capacity

800, 1000, 1200, 1500, 1800L capacity, 12, 15m boom

Leading choice in linkage



Forward angling



No angling



Backward angling

### TWIN STREAM delivers more capacity and saves

The HARDI TWIN STREAM is the most proven spraying system in the world and has verifiable reliability. A unique air-assisted sprayer that provides unbeatable drift control and the highest work rate.

A curtain of air evenly distributed from under the boom carries the spray droplets to the target reducing drift and increasing coverage. Under optimum use the TWIN STREAM can deliver increased capacity and significant saving in plant protection chemicals.

The TWIN STREAM focus is on maximising the work rate and providing the ultimate guidance of crop chemical to the target. The TWIN STREAM system has been tested by farmers and research institutes worldwide. It has gained approval for the application of fine spray droplets in difficult weather conditions and at high driving speeds to achieve the best coverage.

HARDI TWIN STREAM is an excellent spraying concept, guiding the spray drops with air and avoiding drift. The air speed and delivery angle of the air curtain are controlled by the operator to suit the spraying conditions or to significantly increase the coverage and penetration into the canopy. Spray angle can be adjusted from 40° forward to 30° rearward.

Water rate can be reduced from conventional volumes with HARDI TWIN STREAM. This means less water cartage and less filling time. The risk of drift is minimized with active air. The spraying time in each given day can be extended in most cases because TWIN STREAM maintains an excellent cross distribution in windy conditions.

Better coverage, penetration and a higher on target dose rate gives a better result for the chemical. Depending on the crop, significant savings on chemical costs can be realised which is a financial advantage plus an environmental benefit.

Tank size and boom configurations can be uniquely tailored to suit individual spraying needs.

- 800, 1000 1200, 1500 & 1800L capacity
- 12 & 15m boom choice
- Integrated chassis and slim line polyethylene tank
- Integrated quick hitch system
- Manifold fluid system
- Side access step
- Positive displacement diaphragm pump, can run dry without harm
- EVC operating unit
- Self Cleaning delivery filter
- Hydraulic boom height control

FCI	Tank	Boom	Fold	Control	Pump	L/m	RRP
	1000	12TWIN Stream	Hyd	EVC/3	363	194	\$42,055.93
	1200	15TWIN Stream	Hyd	EVC/5	363	194	\$45,454.29
	1500	15TWIN Stream	Hyd	EVC/5	363	194	\$48,368.87
	<b>Optional</b>						
	25 Ltr Chemical Filler with rinse nozzle						\$2,179.11
	15 Ltr Clean Water Tank						\$226.35
	1 x 80 litre rinse/flush tank, & rinse nozzle						\$450.64
	HC5500 Controller						\$3,333.48
	TWIN air speed remote control						\$4,422.00



### Controller

Optional HC2500 or HC5500 compact rate controller is GPS compatible.



### 363 pump

Diaphragm rotary pump with dry sump for easy service, rated to 20 Bar. Delivers 140 litres per minute. Can run dry w/o damage.



### Manifold fluid system

High capacity modular fluid system with slide pin and radial seal connection.



### TurboFiller & TurboDeflector

Optional high capacity hopper for fast, safe mixing and transfer of crop materials.



### Tank

Easy access, high-impact UV resistant polyethylene tank with deep sump to ensure complete emptying.



### Rinse Tank

80L clean water tank for in-field rinsing and cleaning.



### Air angle control

Spray angle can be adjusted from 40° forward to 30° rearward.



### Air speed & angle switch box

Optional air speed control from the cab

# CAT 3

## For maximum durability

1200 & 2000L capacity, 18, 20, 21, 24, 28, 30m boom

Leading choice in linkage



The **CAT 3 Linkage** sprayer is designed to deliver high work rates and excellent performance under the most demanding conditions. Ideal for cotton, row crop, horticultural and broadacre applications. The CAT-3 is a heavy duty construction, with capacity of 1200 & 2000L tanks and 18 to 30m EAGLE booms. The EAGLE boom is standard with hydraulic fold and height control. Individual wing tilt option provides the versatility to use wider booms when turning at the head lands and over irrigation channels. In-cab remote SprayBox controls main on/off, pressure & section valves.

HC5500 spray rate control option provides precise application regardless of forward speed. The fluid system is driven by a HARDI diaphragm pump or Hypro centrifugal pump through manifold valves which can be expanded to provide for dual tank operation. Features:

- User friendly, easy to operate
- Robust heavy duty construction
- Individual boom wing tilt option
- Smooth ride coil spring trapeze boom suspension
- Excellent crop clearance with hydraulic boom height control
- Positive motor drive control valves
- Fluid system is designed to accommodate dual tank operation
- Boom fold ideal for nozzle droppers
- Safe chemical transfer optional ChemFiller

**FCI CAT 3 Linkage**  
Price examples only. Contact your dealer for further configurations.



1200, 18m EAGLE Boom	\$ 42,763.49
2000, 24m EAGLE 3 x 8m sections	\$ 49,727.18
EAGLE boom options include 18, 20, 21, 24, 28, 30m	
<b>Options include</b>	
HC5500 rate controller	\$4,288.90
Jobcom for ASC and VRA	\$2,504.70
Filtered fast fill	\$423.50
Solenoid end nozzle assembly	\$408.10
Boom end guards	\$326.70
Boom line filters each	\$270.60



**FRONT TANK** of 1400 litre increases the overall capacity while optimizing weight distribution. The shape provides an unobstructed view for the operator and a fold away step provides easy access. Maximise spraying capacity to 3400 litres by combining with a 2000L CAT3

<b>FCI</b> 1400 litres	5901721	\$5,225.00
<b>Options include</b>		
EVC/3 Hypro pump unit with operating unit, filter, valves, agitators, drain and 100mm pressure gauge.	5904503	\$5,487.60
Chemical Free Remote Level Indicator	729008	\$370.01
Twin Tank Plumbing Electric Ball Valves	70009704	\$749.13
HC 5500 Controller		\$4,288.90
1-1/2" top to bottom fast fill	70009904	\$161.67

## Nozzles for optimum distribution

<p>F .03 at 3 Bar</p>  <p>65 L/ha at 15 kph</p>	<p>LowDrift .03 at 3 Bar</p>  <p>65 L/ha at 15 kph</p>	<p>MINIDRIFT .03 at 3 Bar</p>  <p>65 L/ha at 15 kph</p>
--	---	---



**Operating unit**  
EVC pressure regulation and boom distribution valve with positive motor drive control.



**Controllers**  
Optional HC5500 compact rate controller is GPS compatible.



**Manifold fluid system**  
High capacity modular fluid system with slide pin and radial seal connection.



**Front Tank**  
1400L tank for extended spraying. Optimised weight distribution

# RANGER Row Crop

Saving time and making spraying easy

2500 litre capacity, 12 to 24 metre booms

Class Leading Sprayer

**New!**



### Track following steering drawbar option

Allows the trailer to follow the tractor in and out of the rows in the same wheel tracks as for the tractor, with hydraulic track correction option



RANGER Row Crop simplicity and reliability will save time and make spraying easy. A completely integrated sprayer providing increased capacity, excellent crop clearance and a low centre of gravity. 2500 litre capacity with booms to 21 metres, a 1.56 to 2.34m adjustable track width and paralift boom height control to 1.75m. The tank shape provides excellent weight distribution and is designed for effective agitation. A foot step and hand rail makes easy and safe access to the platform.

A comprehensive range of booms available include HYS, FlexForce, PRO, TWIN STREAM and EAGLE makes it possible to configure a sprayer to suit any application.

The manifold fluid system has colour coded position icons to make operation easy. Pressure regulation and boom section valves are operated from the tractor seat with the SprayBox remote control. Optional HC5500 controller provides precise application regardless of forward speed.

Options such as the 250L rinse tank enable quick, easy in-field clean-out and a TurboFiller for fast, safe transfer of crop protection products.

### Features:

- 2500L main tank (av 2750 litres) & 19L integrated clean water tank
- Boom widths from 12 to 21m
- Lowest centre of gravity in its class
- 1.56 to 2.32m track width adjustable
- 0.5 to 1.75m paralift boom height control
- Manifold valve fluid control, easy control & maintenance
- Optional 250L flush tank and rinse nozzles integrated over the axle
- Excellent content agitation
- Self cleaning CyloneFilter
- Optional manual / hydraulic track following steering drawbar

**FCI** Price examples only. Contact your dealer for further configurations.

2500 - 12m HYS - 11.2 x 48 tyres - EVC - 363 pump - with optional steering drawbar	From \$42,801.87
2500 - 15m Twin - 11.2 x 48 tyres - EVC - 363 - pump with optional steering drawbar	From \$58,789.94



### Controller

Standard SprayBox control with optional HC 5500 rate controllers which is compact, and GPS compatible.



### TurboFiller with TurboDeflector

Optional high capacity hopper for fast, safe mixing and transfer of crop materials.



### RinseTank

Optional 250L tank is mounted over the axle to optimise weight distribution.



### Rinse nozzles

Fast, efficient tank cleaning with optional rotating rinse nozzles.

# RANGER

## Sensational boom ride

2500 litre capacity, 12 to 21 metre booms

Class Leading Sprayers



Spray on time with reliability you can count on. RANGER is a heavy duty sprayer suitable for row crop, cereals, pasture renovation and horticultural applications. Increase productivity with 2500 litre capacity and booms to 21 metres.

A completely integrated design delivering low centre of gravity, 70cm of crop clearance, 1.56 to 2.34m track width adjustment and paralift boom height control to 1.75m.

The tank shape provides excellent weight distribution and is designed for effective agitation.

A foot step and hand rail makes easy and safe access to the platform.

Booms options include the EAGLE 15, 18, 20, 21m.

The manifold fluid system has colour coded position icons to make operation easy. Pressure regulation and boom section valves are operated from the tractor seat with the SprayBox remote control.

Optional HC2500 or HC5500 controller provides precise application regardless of forward speed.

Options such as the 250L rinse tank allows for quick, easy in-field clean-out and a TurboFiller for fast, safe transfer of crop protection products.

- 2500 litre with over capacity
- Boom widths from 15 to 21m
- Positive motor drive boom distribution valves
- Lowest centre of gravity in its class
- Strong integration of chassis, axle and paralift towers
- 70cm under-axle crop clearance
- 1.56 to 2.32m track width adjustable
- 0.5 to 1.75m paralift boom height control
- Manifold valve fluid control, easy maintenance
- Easy control over filling and cleaning
- Optional 250L flush tank and rinse nozzles
- Flush tank integration over the axle to optimise weight distribution
- 19L integrated clean water tank
- Easy and safe access to the platform
- Excellent content agitation



- Self priming positive displacement diaphragm pump can run dry without damage
- Self cleaning CycloneFilter
- High capacity chemical transfer with optional TurboFiller

**FCI** Price examples only. Contact your dealer for further configurations.

2500, 18 Eagle, 14.9 x 28 tyres, EVC, 1303 pump	From \$43,373.99
2500, 21 Eagle, 14.9 x 28 tyres EVC, HC5500, 363 pump	From \$50,424.23



### Controller

Standard SprayBox control with optional HC 2500 or HC 5500 rate controllers which are compact, and GPS compatible.



### Pump

The fluid system is driven by robust grease-lubricated cast iron diaphragm pump.



### Manifold valves

Centrally located fluid direction control, easy to use, maintain and is expandable.



### TurboFiller with TurboDeflector

Optional high capacity hopper for fast, safe mixing and transfer of crop materials.



### CycloneFilter

Self-cleaning pressure filter uses a high speed cyclone action to improve cleaning.



### In-Line filter

Optional easy service In-Line boom filters eliminate the need for nozzle filters.



### RinseTank

Optional 250L tank is mounted over the axle to optimise weight distribution.



### Rinse nozzles

Fast, efficient tank cleaning with optional rotating rinse nozzles.

# NAVIGATOR

## Smooth ride suspension

Tank capacities: 3000 & 4000 litre  
Boom sizes: 18, 20, 24, 28 & 30m

# Class Leading Sprayers



NAVIGATOR integrated spraying solutions optimise application efficiency and deliver better productivity. Designed to cope with tough broadacre and row crop spraying conditions, the 3000 & 4000L capacities and booms to 30m deliver the reliability you can count on. Spraying has never been so smooth, quick and easy.

The tank and chassis is completely integrated and has a front platform for easy access to the main tank. The 450L rinse tank is positioned over the axle for extra stability.

70 to 80cm crop clearance with a low centre of gravity. The drawbar is fixed directly to the axle and absorbs vertical forces at high speeds.

Three axle options provide adjustability from 1.5 to 2.25m and there is a 3m fixed option.

Axle suspension delivers smooth trailer performance, a better boom ride and more accurate product application.

A wide, stable paralift gives effortless boom height control to 2.2m.

Two SmartValves provide control of all the primary operating functions, and the fluid system is driven by robust grease-lubricated cast iron diaphragm pump.

Chemical transfer with the optional TurboFiller uses a TurboDeflector inside the hopper for rapid mixing.

- User friendly easy to operate
- 70 to 80 cm under-axle crop clearance
- Low centre of gravity
- 3000L or 4000L capacity
- 18 to 30m booms
- Easy access platform for tank inspection
- 1.8 to 2m fixed axle track width with 1.5 to 2.25 m adjustable option and 3m fixed option

- Self priming diaphragm pump can run dry without damage
- SmoothRide suspension option
- Fast paralift boom height control
- Integrated main tank, flush tank and chassis design
- Optimised weight distribution with flush tank positioned over the axle
- High capacity filtration through EasyClean suction and Cyclone self cleaning filters
- Primary function control with SmartValves
- Optional safe and easy chemical transfer through the TurbFiller or Granni Pot
- Positive motor drive boom distribution valves
- SprayBox control is standard with HC2500 or HC5500 spray rate controllers optional
- Unsurpassed boom performance in rough conditions

**FCI** Price examples only. Contact your dealer for further configurations.

3000, 18 Eagle, 18.4x 30 tyres, EVC, 363	From \$53,770.20
4000, 30 Eagle, 18.4 x 38 tyres, EVC, HC5500, 363, suspension	From \$78,437.87



### Controller

SprayBox & optional spray rate controller is compact, user friendly and GPS compatible.

### SmartValve

Filling and cleaning is controlled by a colour coded valve for easy operation.

### TurboFiller with TurboDeflector

Optional. Mixes and transfers large quantities of powders and liquids fast and efficiently.

### SmoothRide option

Suspension provides a better ride for the sprayer and boom, improving application precision.

## Nozzles for optimum distribution

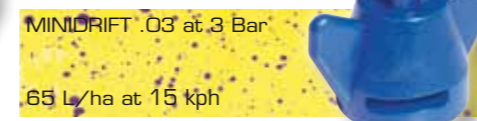
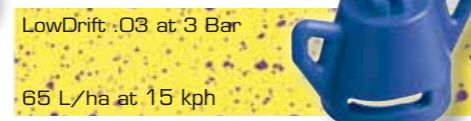



# COMMANDER

## Capacity to spray longer

5000, 7000, 9000L tanks  
TWIN FORCE 18- 30.5m,  
FORCE 24 - 36m  
EAGLE 18 - 30m

## Class Leading Sprayers



COMMANDER 5000, 7000 & 9000 litre capacities and booms to 36m deliver high work rates to make spraying faster and more efficient. A fully integrated design optimises strength and weight to deliver robust reliability. COMMANDER performance and boom ride ensure precision every time.

The fluid system is managed from the 'WorkZone' providing easy control over filling and cleaning.

The integrated tank and chassis provide a low centre of gravity and excellent crop clearance.

Compact hydraulic axle suspension provides a smooth trailer ride with less roll than air suspension.

For rotobucks, a tandem walking beam axle option is available.

The 5000 and 7000 can be fitted with SafeTrack steering, while the 7000 and 9000 chassis have integrated drawbar suspension.

Chemical transfer is through a ChemFiller or GranniPot. A high capacity EasyClean suction filter is monitored by an external gauge, and the CycloneFilter ensures only the cleanest fluid gets to the nozzles

- Heavy duty integrated tank and chassis design
- All primary functions within easy reach
- SmartValves provides easy control over filling and cleaning
- EasyClean suction filter with vacuum gauge
- Easy access platform for tank inspection
- Draw bar suspension on 7000 & 9000
- SafeTrack and Walking Beam axle available on 5000 & 7000
- Brakes available for road use
- Excellent under axle crop clearance
- Hydraulic axle suspension ensures less roll
- ParaLift boom height control, 0.4 to 2.2m
- Tank bottom slopes forward, maintaining weight on the draw bar while emptying
- Optimised weight distribution with flush tank positioned over the axle
- HC5500 & HC6500 controllers have all frequently used functions at the fingertips
- CycloneFilter with high speed self cleaning cyclone action
- Positive motor drive boom distribution valves
- Intelligent sprayer feature provide greater precision



*Price examples only. Contact your dealer for further configurations.*

Model	Prices from
5000, 30 Eagle, 18.4 x 38 tyres, susp., 463 pump	\$103,747.60
5000, 24.5 T/Force, 18.4 x 38 tyres, fixed, 463 p	\$133,596.10
5000, 30.5 T/Force, 18.4 x 38 tyres, susp., 463 p	\$149,799.10
7000, 36 Force, 20.8 x 42 tyres, Susp, 463 pump	\$145,614.70
7000, 30.5 T/Force, 20.8 x 42 tyres, Susp, 463 p	\$168,048.10
9000, 36 Force, 710 x 42 tyres, Susp, 463 pump	\$174,310.40



**HC5500 / Optional HC6500**  
Compact rate controller, GPS compatible.



**SmartValves**  
Filling and cleaning is controlled by two colour coded valves for easy operation.



**TWIN FORCE**  
A curtain of air from under the boom carries the spray droplets to the target reducing drift and increasing coverage.



**SafeTrack**  
Optional track following with dynamic stability control for 5000 & 7000L.

# ALPHA

## Capacity, coverage & comfort

2500, 3400 & 4100L capacities.  
FORCE booms to 36m & TWIN FORCE to 30.5m



### ALPHA and ALPHA TWIN FORCE

The ALPHA is a light weight go-anywhere self-propelled sprayer with Deutz engine and hydrostatic transmission. It is a well balanced sprayer offering coil spring suspension, 4 wheel steer and 4 wheel drive. The ALPHA can be ordered with fixed track or variable track width option, is available in tank sizes 2500, 3400 and 4000 litres and boom widths to 36 metres. Features

- 2500, 3400 and 4100 L capacity
- 4WD and 4WSteer standard
- Comfortable cab, superb all-round view
- Reduced cab clutter with HC6500 controller
- Easy and safe access to all fluid components
- EasyDrive function with integrated Cruise Control
- Higher work rates and better operating efficiency
- Multifunctional joystick for driving, spraying and hydraulic control
- Excellent clearance 1.08 m to 1.25 m depending on model
- A special "sweet corn" version with 1.55 m clearance is available
- FORCE boom up to 36m, TWIN FORCE boom up to 30.5m
- Aluminium boom up to 38m
- Easy access to all service points, engine and transmission

Price on application **Enquiries 1300 042 734**



### TWIN

The HARDI TWIN boom offers the ultimate in capacity and weather independence. A curtain of air from under the boom guides the spray droplets to the target, reducing drift and increasing coverage. Air speed and delivery angle is controlled by the operator to suit the spraying conditions, significantly increasing coverage and penetration.

TWIN can achieve a 100% increase in capacity and a 30% saving in plant protection chemicals.



# SARITOR series 1

## Reliable simplicity

4800L capacities.  
FORCE booms to 36m

# Coming soon SARITOR series 2



**Runout specials!**

**From \$327,184.00**  
Stock is limited at this price!



### DirectCommand

Providing for spray rate, mapping, variable rate, AutoSection, boom height, auto steer, direct injection & dual product control.



### TurboFiller

A powerful liquid rotation and venturi vacuum combine to deliver a transfer rate of up to 30kg per minute.



### SARITOR DirectCommand

Heavy duty 4800 litre mechanical drive self propelled sprayer with 275 hp Cummins engine, Allison auto transmission, JCB differential and Fairfield final drives. A high capacity sprayer built for fast turn around with ground control switching, drop down fluid module, TurboFiller, CycloneFilter, wash down hand gun, fast rate control, EFC section distribution and DirectCommand.

- Owners worry 40 - 60% less about fuel cost
- Prime mover platform can be used for other operations
- Reduced cab clutter with DirectCommand
- Easy and safe access to all fluid components
- Ground control switching saves climbing back up to the cab
- Higher work rates and better operating efficiency

- More efficient use of hp through the mechanical drive train
- Greater economy...doesn't require maximum engine revs all the time
- Smooth through the ranges and easy to drive
- Repairs and maintenance are easily carried out on farm
- Cheaper maintenance than hydrostatic transmissions
- 70kph means less down time and faster turn around between fills
- Excellent visibility to the crop and over the tank
- On-the-go track width adjustable
- High flotation tyres and dual wheel options
- Will keep its value for years to come

**Enquiries 1300 042 734**

## ZENIT & ZATURN Vine

Maximum efficiency

### Compact & efficient

600L ZENIT capacity  
1500 & 2000L ZATURN capacity



**ZENIT & ZATURN hydro pneumatic vine sprayers** use conventional hydraulic nozzle application for single and two row spraying. Adjustable air outlet direction converges air onto the target zone, minimising drift. Hydraulic nozzles are used for medium to high volume application. Choice of single row B11 & two row B20 hydraulic or manual fold booms

- On/off control at each air outlet
- Adjustable air outlet direction
- Converges air onto target zone
- Minimises drift
- 3 nozzle outlet standard

#### FCI ZENIT Hydro Pneumatic with 321/10 pump

Model, air kit	Control	RRP
600, P540 Turbine, B11 / HH1	M70/2	\$18,733.70
600, P540 Turbine, B11 / HH1	EVC/2	\$20,117.93
600, P540 Turbine, B20M / CC	EVC/2	\$26,900.71

#### FCI ZATURN Hydro Pneumatic with 363 pump

1000, P540 Turbine, B11 / HH1	MC/2	\$24,451.23
1500, P540 Turbine, B11 / HH1	EVC/2	\$28,148.20
2000, P540 Turbine, B11 / HH1	EVC/2	\$29,494.34
1500, P540 Turbine, B20H / CC	EVC/2	\$33,890.44
2000, P540 Turbine, B20M / CC	EVC/2	\$32,484.76
2000, P540 Turbine, B20H / CC	EVC/2	\$35,236.59

**FCI ZENIT CANNON high volume applicator** for crops with difficult spraying conditions, providing coverage up to 12 metres vertically and 27 metres horizontally.

- Heavy duty two speed gear box

400 P540 CANNON-L 321/10	M70/2	\$17,871.55
600 P540 CANNON-L 321/10	M70/2	\$18,419.20
600 P540 CANNON-M 363/7	EVC/2	\$21,299.29



#### Cannon

Hydraulic verticle air outlet adjustment with 180 degree orientation



#### Cannon spout options

Different spouts are available to provide optimum coverage

## COVAMAX

Maximum efficiency

### Powerful delivery minimum drift

2300, 3300 & 4000L capacity



**COVAMAX with HF600 Turbine, Two Row Boom** provides exceptional drift control, canopy penetration and coverage is achieved through adjustable converging air angles, for versatile low and high volume applications. COVAMAX is designed for high air volumes application with low horsepower consumption.

- Heavy duty integrated tank and chassis
- High performance HF600 fan
- Heavy duty gear box & clutch
- Adjustable track width
- Adjustable air outlet orientation
- Individual air outlet fluid control
- Maintenance free boom design
- Optional HC3500 cab controls
- Choice of HARDI 363/7 diaphragm pump or AR200

FCI	Model	Pump	Control	RRP
	2300	363	EVC/2	\$50,550.50
	3300	363	EVC/2	\$52,853.90
	3800	363	EVC/2	\$55,778.80

#### Optional

Suspension 2300	\$2,280.33
Suspension 3300	\$2,280.33
Brakes, suit 3300/4000 only	\$788.70
Pressure filters x2	\$114.40
Powder mixer	\$167.20
Turnable drawbar, in lieu of standard	\$1,634.60
Wide angle PTO shaft, in lieu of standard	\$1,266.10

Hydraulic wng tilt and adjustable row width options are available on request. Talk to your HARDI dealer about these solutions.



#### Controller

HC 3500 Rate controller especially designed for mistblowers allows more precise application.



#### Turnable drawbar

Optional turnable drawbar and wide angle PTO shaft for manouering on tight headlands.

## ZEBRA

Practical efficient & economical

200, 400, 600 & 800L capacity



**New!**

## NEPTUN

Practical efficient & economical

1000 & 1500L capacity



**New!**

**ZEBRA** axial is a small mistblower with big versatility, designed for use in orchards, plantations, bush and trellis crops.

- 200, 400, 600 & 800L capacity
- AA 550, 650, 750 & 820mm axial fan
- Integrated tank and frame
- Low centre of gravity

FCI Model	Air kit	Control	RRP
200	AA550 Axial blower	M70/2	\$5,885.00
400	AA650 Axial blower	M70/2	\$6,200.70
600	AA650 Axial blower	M70/2	\$6,679.20
600	AA750 Axial blower	M70/2	\$7,418.06
800	AA820 Axial blower	M70/2	\$8,847.13



## ZENIT - Compact & efficient

400 & 600L capacity

ZENIT axial mistblowers with 321/10 pump deliver superior air performance for better coverage and penetration. Designed to improve air distribution with less noise and low horsepower consumption.

- Integrated tank and frame
- Low centre of gravity
- Synthetic axial fan blades
- Centrifugal clutch
- Gearbox with neutral position

FCI Model	Air Kit	Control	RRP
400	AG750 Axial blower	M70/2	\$13,311.82
400	AG750 Axial blower	EVC/2	\$14,696.04
600	AG820 Axial blower	M70/2	\$14,307.30
600	AG820 Axial blower	EVC/2	\$15,691.53



## Mistblower

**NEPTUN** axial mistblowers are ideally suited to tree and vine crop spraying. Features:

- Strong integrated tank and chassis design
- Axial bladed fan choice of 750, 820 & 920 mm
- 12 nozzle holders with ceramic 1299 nozzles
- Two speed gear box with neutral position
- Self priming positive displacement diaphragm pump
- Low power consumption 50hp
- High quality surface treatment & powder coating
- Choice of electric or manual operating unit
- Large suction filter
- Tyres 1000: 10/80 - 12-8PR  
1500: 10/75 - 15-12PR
- Optional V deflectors

FCI Model	Air Kit	Control	RRP
1000	AA750 Axial blower	cable	\$15,404.31
1500	AA750 Axial blower	cable	\$19,749.83
1500	AA820 Axial blower	cable	\$20,149.63
Electric solenoid option			\$1,500.00



# ZATURN

## High performance

1500, 2000, 3000L capacity

# Performance Mistblower

**New!**



# MERCURY

## The ultimate performance

2300, 3300, & 3800L capacity

# Performance Mistblower



**ZATURN axial mistblowers** suit a wide range of crops ideal for optimising the spray coverage in small bush and large tree. An adjustable blower with 2 speed gearbox and 3 fan blade settings will deliver superior air performance for coverage and penetration.

- Integrated tank and frame
- Low centre of gravity
- Synthetic axial fan blades
- Centrifugal clutch, gearbox with neutral position

Model	fan size	Control	RRP
1500, AG820 Axial blower, EVC/2, 140 L/m	AG820	EVC/2	\$21,980.20
2000, AG820 Axial blower, EVC/2, 140 L/m	AG820	EVC/2	\$23,326.97
3000, AG820 Axial blower, EVC/2, 140 L/m	AG820	EVC/2	\$26,355.03

### Options

V-Deflectors for axial fans	\$100.10
DUO T-Deflector for AG820 axial fans	\$2,423.30
DUO V-Deflector for AG820 axial fans	\$2,918.30
Double nozzle holder	\$579.70
Powder mixer	\$167.20



**MERCURY axial mistblowers** offer powerful and efficient performance for the effective treatment of tree crops. High performing air kits provide the finest air distribution for a perfect application. Mercury heavy duty gear box, straightening vanes, synthetic fan blades, and dual core housing delivers more uniform air more efficiently than other combinations.

- Fan straightening vanes
- Synthetic fan blades
- Nozzle located outside airstream

Model	fan size	Control	RRP
2300, SF65 Axial blower	SF65	EVC/2	\$26,639.80
3300, SF65 Axial blower	SF65	EVC/2	\$28,943.20
3800, SF65 Axial blower	SF65	EVC/2	\$34,898.60

### Optional

SF-65 Jet Deflector	\$4,062.30
SF-65/85 Match Deflector	\$855.80
V-Deflectors	\$246.40
Bottom Deflector	\$114.40
Adjustable Bottom Deflector	\$579.70
DUO T deflector	\$2,449.70
DUO V deflector	\$2,979.90



## Pumps & pump repair kits

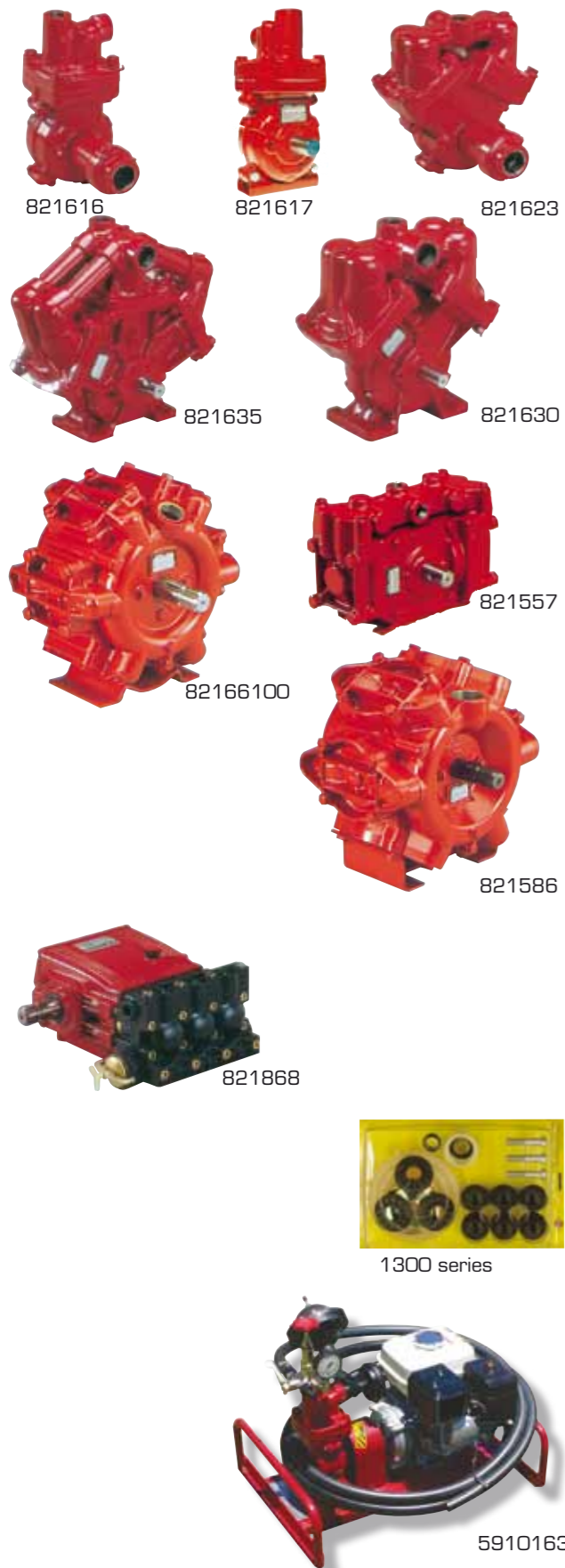

<b>Diaphragm Pumps</b>	Flow L/m	Part No	RRP
503 with PTO coupling and chains	16	821616	\$539.65
503/4 (1000 rpm) with foot	16	821618	\$484.00
503 HP (25 bar)	16	821026	\$495.00
503 with foot	16	821617	\$484.00
603 with PTO coupling and chains	31	821623	\$948.37
603 with foot	31	821624	\$839.07
603/4 (1000 rpm) with foot	31	821625	\$831.11
1203 with foot	99	821630	\$1,236.41
1203/6 (1000 rpm) with foot	108	821629	\$1,495.99
1303 with foot	114	821635	\$1,835.26
1303/6 (1000 rpm) with foot	136	821634	\$2,080.04
321 HP (25bar) with foot	51	821557	\$1,244.38
363 540 rpm, 1 1/2" suction-1" delivery	194	82166100	\$2,813.23
363 540 rpm, 1 1/4" suction-1" delivery	194	821579	\$2,813.24
363/5.5 (1000 rpm) foot, 1 1/2" suction - 1" delivery	201	821651	\$3,225.37
363/5.5 (1000 rpm) foot, 1 1/4" suction - 1" delivery	201	821574	\$3,225.37
363 540 rpm through shaft, 1 1/4" suction - 1" delivery	194	821580	\$3,010.19
363/7 20 bar 540 rpm through shaft, 1 1/4" suction - 1" delivery	140	829496	\$3,010.19
463/10 540 2" suction - 1 1/4" delivery	276	821586	\$3,795.00
463/10 540 rpm through shaft, 2" suction - 1 1/4" delivery	276	821587	\$3,991.96
463/5.5 1000 rpm 2" suction - 1 1/4" delivery	305	821584	\$4,403.36
463/12 540 rpm no feet 2" suction - 1 1/4" delivery	322	7229300	\$3,795.00
Pulsator kit for 500/600/321 pump		727864	\$206.07
Pulsator kit for 1202/1302 pump		727861	\$218.59
Pressure Pulsator , complete		845014	\$174.19
Suction Pulsator , complete		703032	\$45.56
<b>Pump Kit</b>			
PTO 503 Pump kit with brass op. & pulsators	16	5905200	\$888.03
PTO 603 Pump kit with brass op. & pulsators	31	5905201	\$1,285.37
<b>Piston Pumps</b>			
PS3X 60 bar spline/cone	70	821868	\$2,570.53
<b>Repair Kits</b>			
For 500 - 503 series pump		Refer to	\$84.91
For 600 -603 series pump		the pump's	\$171.93
For 1200 -1203 series pump		ID plate	\$283.49
For 1300 - 1303 series pump		for correct	\$401.89
For 360 - 363 series pump		series pump	\$778.73
For 460 - 463 series pump		repair kit	\$897.14
<b>Pump units</b> Direct-coupled to Honda, pressure regulation & bypass control			
4 hp Brass, 503, 16 L/m		5910163	\$2,272.68
4 hp Brass, 603, 31 L/m		5910165	\$2,499.52
5.5 hp Brass 25 bar, 321, 50 L/m		5910167	\$3,123.33
5.5 hp 1203, 99 L/m		5910166	\$3,123.33
9 hp* 363, 194 L/m, BK 180 control * electric start		5910172	\$5,618.57

## Operating units & controllers



<b>Manual operating units</b>	Part No	RRP
Brass operating unit with gauge & pulsators	727862	\$607.96
M70 operating unit - bare	841013	\$564.70
BK 180-3 operating unit	841902	\$1,069.05
12 volt relief valve and gauge kit	84100004	\$186.71
<b>SC solenoid operating units with manual pressure control</b>		
3 section SC operating unit	840107	\$1,960.50
<b>SC solenoid operating units, electric pressure control &amp; HC2500 controller</b>		
3 section SC/EC-HC2500 controller	842255	\$6,069.34
4 section SC/EC-HC2500 controller	842256	\$6,262.89
<b>Build your own EVC control unit. Choose from the following</b>		
<i>Includes; Switch box, Junction box, gauge, fittings, mounting bracket and electric flow control valve. Choose number of sections. Add cable length.</i>		
3 section EVC, with electric flow valve	84101104	\$3,270.93
4 section EVC, with electric flow valve	84101204	\$3,446.65
6 section EVC, with electric flow valve	84101004	\$3,852.14
8 section EVC, with electric flow valve	84101304	\$4,730.70
<b>Cable from tractor cab to distribution valves. Choose length</b>		
5 m cable	28028800	\$293.73
8 m cable	28028900	\$323.33
14 m cable	28028700	\$536.23
17 m cable	26004200	\$659.19
<b>Monitor controller kit</b>		
2500 controller	840166	\$2,310.02
5500 controller	840167	\$2,841.70
<b>Transducer kit</b>		
Flowmeter/Speed Transducer kit	840169	\$865.20
<b>Tractor mounting bracket kit for monitor/controller</b>		
2 pole	72236500	\$166.22
3 pole	72050000	\$187.85

## Spraying accessories



<i>Calibration kits include jug, calibration disc, nozzle brush, spray technique booklet.</i>		
Kit for field sprayers (ISO nozzles, 110 degree)	818492	\$65.18
Kit for mistblowers	818207	\$91.30
Calibration disc, (ISO nozzles & 4110, 110 degree)	285802	\$27.26
Calibration disc, Mistblowers (1299 series nozzles)	284554	\$43.74
Sprayer test paper, 50 pieces	893211	\$40.58
<b>3-way manifold</b>		
3-way manifold, complete with 1/2" tails	5905111	\$183.33
<b>Filters</b>		
1/2" barbed line filter, 100 mesh, (HARDI)	845207	\$38.93
3/4" barbed line filter, 100 mesh, (HARDI)	845210	\$38.93
<b>Floating filter</b>		
Floating filter with 1-1/2" tail	841481	\$321.06
<b>Self-cleaning filters</b>		
Self-cleaning filter, 80 mesh	845193	\$299.43
Self-cleaning filter, 50 mesh	845194	\$299.43
Self-cleaning filter, 100 mesh	845195	\$299.43

## Granni Pot

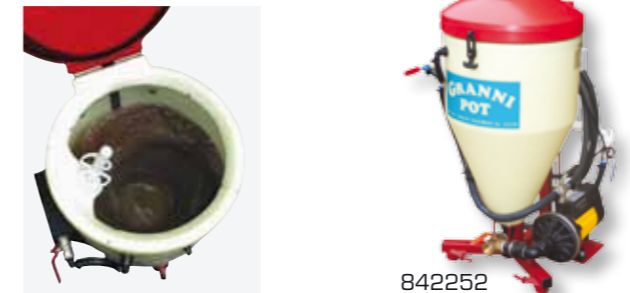

Great Granni Pot (with 240 V Davey)	842252	\$2,672.96
Granni Pot Ground Station	842251	\$2,001.49
Granni Pot with drop-down bracket	842253	\$2,001.49
Vacuum kit for Granni Pot	5912190	\$493.27
Plumbing kit to suit 842253	5912193	\$1,167.33

# Booms & accessories



ATV



Under Vine



SB



MB



FALCON



EAGLE



824167

824168



Description	Part No	RRP	
<b>Hose reel</b>			
20m hose reel, no hose, 12 bar	74100404	\$309.67	
30m hose reel, 30m 3/8 hose	28026204	\$297.00	
30m hose reel, 30m 3/8 hose & 60S gun	81800404	\$467.50	
50m hose reel, no hose, 25 bar*	818377	\$398.48	
100m hose reel, no hose, 25 bar*	818381	\$409.86	
*50/100m hose reel mounting bracket	834764	\$86.86	
20m hose reel, hose and 60S spray gun	5904101	\$531.30	
50m hose reel, hose and 60S spray gun*	81800304	\$770.76	
100m hose reel, hose and 60S spray gun*	5904112	\$1,102.79	
<b>Spray gun</b>			
Spray gun model 60S, adjustable cone spray, 60 bar	843196	\$170.78	
Spray gun model 60L, adjustable cone spray, 60 bar	843197	\$211.76	
<b>ATV boom</b>			
	Part No	RRP inc GST	
1.5 m fixed	5908100	\$240.22	
2.0 m fixed	5908102	\$286.90	
3.0 m	5908104	\$754.30	
4.0 m	5908105	\$844.61	
<b>Olive &amp; Vine boom with fixed cone</b>			
8 nozzle vine T boom for two half row	5908310	\$740.03	
10 nozzle vine T boom for two half row	5908311	\$822.00	
<b>NK &amp; NL under Vine/Tree herbicide boom</b>			
Robust design, adjustable for row width with breakaway & protected nozzles			
Under vine boom LHS	83317404	\$565.83	
Under vine boom RHS	83317504	\$565.83	
Under tree boom LHS	83317704	\$604.54	
Under tree boom RHS	83317604	\$604.54	
Under vine/tree mount kit	83317804	\$87.81	
Under vine/tree centre bar 4 nozzle	83317904	\$262.99	
<b>SB Linkage boom</b>			
6 metre - 12 nozzles	817047	\$1,347.34	
8 metre - 16 nozzles	817062	\$1,772.55	
10 metre - 20 nozzles	817084	\$2,093.98	
6 metre wing set	721755	\$418.97	
8 metre wing set	721766	\$716.12	
10 metre wing set	721777	\$931.29	
Hydraulic height control and trapeze	831272	\$2,070.93	
Hydraulic SB vertical wing lift kit	817928	\$2,892.93	
In lieu of standard SB centre section	5908130	\$2,757.32	
Trapeze suspension kit	727571	\$825.00	
<b>MB boom</b>			
12m, no lift	5908151	\$4,108.85	
12m, hydraulic lift	5908191	\$6,450.74	
Air bag suspension for MB boom	5908160	\$1,292.20	
<b>FALCON boom</b>			
12.5m, hydraulic fold	818402	\$13,437.72	
16.5m, hydraulic fold	818406	\$13,948.90	
Gantry & hydraulic lift	831314	\$2,351.00	
Hydraulic wing tilt kit	834654	\$1,872.83	
<b>EAGLE boom (complete with vertical tower)</b>			
18m, hydraulic fold	818350	\$17,071.81	
18m, hydraulic fold (tilt optional)	818331	\$18,116.95	
20m, hydraulic fold	818351	\$20,350.69	
20m, hydraulic fold (tilt optional)	818332	\$21,396.97	
24m, hydraulic fold (tilt optional)	81856204	\$25,542.25	
28m, hydraulic fold (tilt optional)	81856304	\$27,737.28	
30m, hydraulic fold (tilt optional)	81856404	\$29,532.69	
Tilt cylinders-18/20m Eagle booms	5908258	\$1,676.02	
Tilt cylinder-24/28/30m Eagle booms	833156	\$1,962.77	
<b>Linkage tank and frames L x W x H</b>			
NL300 tank & frame	720 x 800 x 1200	824166	\$1,406.05
NL400 tank & frame	700 x 1120 x 1140	824167	\$1,359.37
NL600 tank & frame	800 x 1120 x 1400	824168	\$2,072.07
NL800 tank & frame	800 x 1600 x 1400	824151	\$2,476.24
300 NL tank only	620 x 800 x 1100	726865	\$744.58
400 NL tank only	640 x 1120 x 1040	726867	\$926.74
600 NL tank only	700 x 1120 x 1300	725930	\$1,219.33
800 NL tank only	700 x 1600 x 1300	725931	\$1,744.18

# Nozzles [www.hardi-nozzles.com](http://www.hardi-nozzles.com)

Saddles	Qty	Part No	RRP inc GST				
Single saddle assembly screw fit	Single	716037	\$16.87				
Single saddle assembly snapfit	Single	725079	\$18.81				
Triplet saddle assembly snapfit	Single	725078	\$29.19				
<b>Saddle &amp; nozzle assembly</b>							
F Series	10 piece	5908903	5908904	5908905	5908906	75501004	\$303.98
LowDrift Series	10 piece	75500004	75500104	75500204	75500304	75500404	\$352.94
MINIDRIFT Series	10 piece	75500504	75500604	75500704	75500804	75500904	\$355.21

Nozzle filter	Mesh	50 mesh	80 mesh	100 mesh	RRP inc GST
Without seal		614366	614367	614368	\$3.37
With seal (suit snap fit)		725043	725042	725044	\$4.67

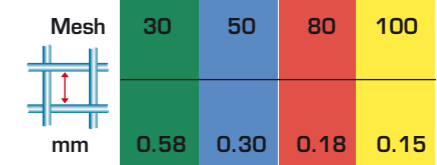

<b>Nozzle fittings</b>		
2 hole boom tube*	612872	\$25.04
3 hole boom tube*	612883	\$37.56
4 hole boom tube*	612894	\$50.08
5 hole boom tube*	612905	\$62.61
* 50cm hole spacing		
3/4 cap	320283	\$3.63
End plug	716413	\$7.14
3/4 hose union	724621	\$5.84
1/2 hose union	716236	\$5.19
1/2 thread union	720856	\$5.12
SF filter gasket	390639	\$2.60
Nozzle cap 3/8	320187	\$3.37
Snap fit cap for cone nozzle	334082	\$1.98
DUOCAP	28063000	\$10.92
Blind Nozzle DUOCAP	372140	\$1.62
Cap to suit ISO nozzles	334083	\$1.97
Gasket when filter not used	242252	\$1.30
Cap to suit TeeJet nozzle bodies	334862	\$1.97
Gasket to suit TeeJet	242222	\$1.84
<b>Blank for snap-fit cap</b>		
Snap fit cap	334082	\$1.98
Blank	334102	\$1.30
Seal	242252	\$1.62
Underleaf dropleg x 1	834278	\$58.39
Underleaf droplegs x 5	834281	\$291.97
<b>Nozzle mounting bracket</b>		
Nozzle bracket	334874	\$11.94
Nozzle bracket mount	334873	\$21.68
Nut	322114	\$1.04
Screw	322116	\$1.04
Nozzle bracket kit complete	833288A	\$29.19

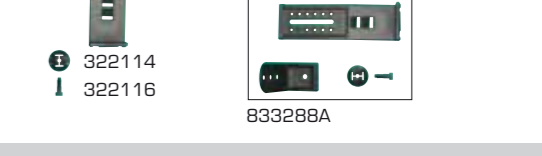
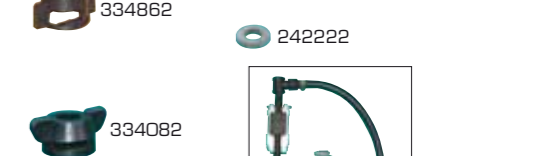
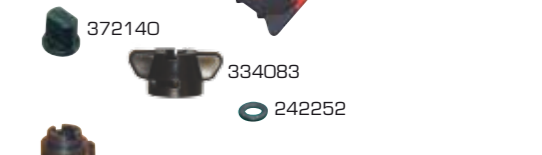
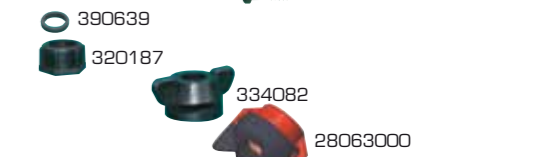
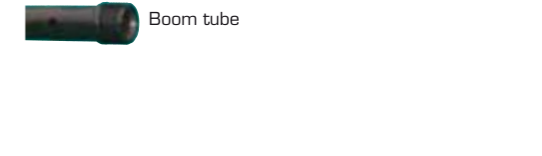
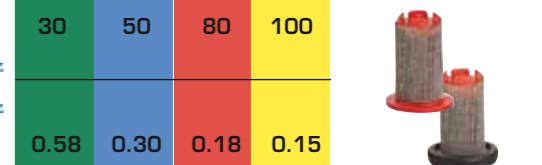
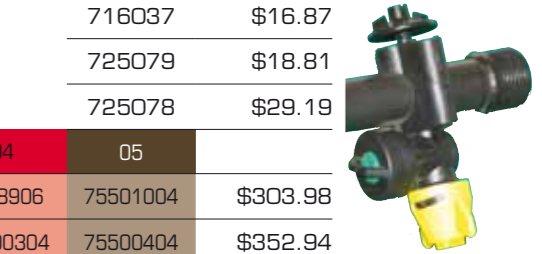



### HARDI ISO F-110 Standard Flat Fan

All-round flat fan nozzle. Recommended for all types of pesticide application where optimum coverage is demanded. This nozzle will give you excellent and uniform liquid distribution at boom heights from 35 to 70 cm (50 cm recommended to take care of uneven terrain or boom movements).

- ISO: Flow, colour and outer dimensions
- Working pressure: 1.5 to 5 bar
- Recommended for TWIN sprayers
- SYNTAL – precision moulded thermoplastic
- CERAMIC – extremely high durability
- COLOR TIPS – for safe and easy handling

.03 at 3 Bar,  
65 L/ha at 15 kph

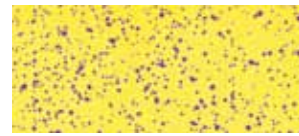

Fine Medium Coarse V.coarse



### HARDI ISO LD-110 LowDrift

LowDrift nozzles are recommended when optimum spraying conditions cannot be achieved (risk of drift) and spraying cannot be postponed.

- ISO: Flow, colour and outer dimensions
- Working pressure: 1.5 to 5 bar
- Restrictor designed for minimum chemical residues
- SYNTAL – precision moulded thermoplastic
- CERAMIC – extremely high durability
- COLOR TIPS – for safe and easy handling

.03 at 3 Bar,  
65 L/ha at 15 kph

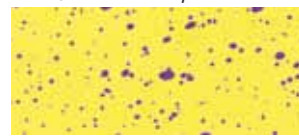

This nozzle will give you excellent and uniform liquid distribution at boom heights from 35 to 70 cm (50 cm recommended to take care of uneven terrain or boom movements).



### HARDI ISO MINIDRIFT Air inclusion nozzles

Nozzle can be used for spraying at sub-optimal weather conditions, when spraying cannot be postponed. The MINIDRIFT nozzle will at low pressures reduce drift to a minimum.

- Air inclusion nozzle
- Working pressure: 1 to 5 bar
- ISO flow, colours, sizes and nomenclature
- Application rates from 60 to 400 l/ha (at 8 km/h)
- SYNTAL – precision moulded thermoplastic

.03 at 3 Bar,  
65 L/ha at 15 kph

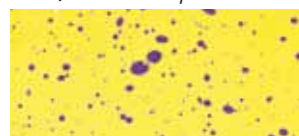

This nozzle will give you excellent and uniform liquid distribution at boom heights from 40 to 90 cm.

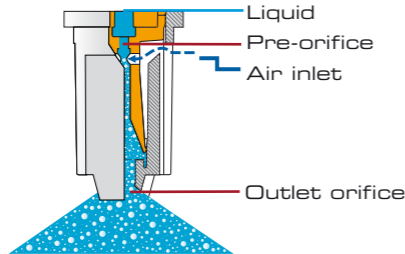

### HARDI ISO INJET Air inclusion nozzles

Nozzles can be used for spraying at sub-optimal weather conditions, or when spraying cannot be postponed. The HARDI INJET nozzles are recommended for most pesticide applications where reduced risk of drift is demanded.

- Air inclusion nozzles with greater drift reduction
- ISO flow, colours and nomenclature
- Application rates from 60 – 600 l/ha (at 8 km/h)
- Pressure range: 3 – 8 bar
- B-Jet border nozzle for precise application near sensitive areas
- Available in SYNTAL and CERAMIC materials

.015 at 5.5 Bar,  
65 L/ha at 15 kph

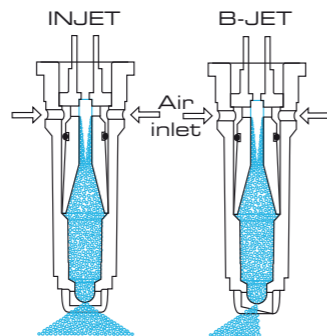
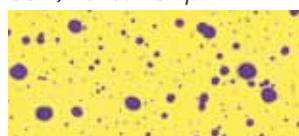

The HARDI INJET & B-JET nozzles

bar	1.5	2.0	2.5	3.0	4.0	5.0
ISO size/colour						
0075-Pink	0.21	0.24	0.27	0.30	0.35	0.39
01-Orange	0.28	0.33	0.37	0.40	0.46	0.52
015-Green	0.42	0.49	0.55	0.60	0.69	0.77
02-Yellow	0.57	0.65	0.73	0.80	0.92	1.03
025-Lilac	0.71	0.82	0.91	1.00	1.15	1.29
03-Blue	0.85	0.98	1.10	1.20	1.39	1.55
04-Red	1.13	1.31	1.46	1.60	1.85	2.07
05-Brown	1.41	1.63	1.83	2.00	2.31	2.58
06-Grey	1.70	1.96	2.19	2.40	2.77	3.10
08-White	2.26	2.61	2.92	3.20	3.70	4.13
10-Light blue	2.83	3.27	3.65	4.00	4.62	5.16

bar	1.5	2.0	2.5	3.0	4.0	5.0
ISO size/colour						
01-Orange	0.28	0.33	0.37	0.40	0.46	0.52
015-Green	0.42	0.49	0.55	0.60	0.69	0.77
02-Yellow	0.57	0.65	0.73	0.80	0.92	1.03
025-Lilac	0.71	0.82	0.91	1.00	1.15	1.29
03-Blue	0.85	0.98	1.10	1.20	1.39	1.55
04-Red	1.13	1.31	1.46	1.60	1.85	2.07
05-Brown	1.41	1.63	1.83	2.00	2.31	2.58

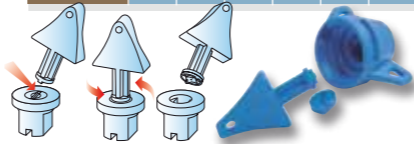

bar	1.5	2.0	2.5	3.0	4.0	5.0
ISO size/colour						
015-Green	0.42	0.49	0.55	0.60	0.69	0.77
02-Yellow	0.57	0.65	0.73	0.80	0.92	1.03
025-Lilac	0.71	0.82	0.91	1.00	1.15	1.29
03-Blue	0.85	0.98	1.10	1.20	1.39	1.55
04-Red	1.13	1.31	1.46	1.60	1.85	2.07
05-Brown	1.41	1.63	1.83	2.00	2.31	2.58

The droplet spectrum is coarse to very coarse; safe for drift control but without risking poor coverage and deposition on leaves. The venturi can easily be removed for cleaning the nozzle.

bar	3.0	4.0	5.0	6.0	7.0	8.0
ISO size/colour						
01-Orange	0.40	0.46	0.52	0.57	0.61	0.65
015-Green	0.60	0.69	0.77	0.85	0.92	0.98
02-Yellow	0.80	0.92	1.03	1.13	1.22	1.31
025-Lilac	1.00	1.15	1.29	1.41	1.53	1.63
03-Blue	1.20	1.39	1.55	1.70	1.83	1.96
04-Red	1.60	1.85	2.07	2.26	2.44	2.61
05-Brown	2.00	2.31	2.58	2.83	3.06	3.27
06-Grey	2.40	2.77	3.10	3.39	3.67	3.92
08-White	3.20	3.70	4.13	4.53	4.89	5.23

can be mounted using the 334083 ISO/INJET cap.



### HARDI ISO QUINTASTREAM

Designed for application of liquid fertilizer. The patented QUINTASTREAM nozzle ensures optimum distribution with overlap. Fertilizer is applied in solid streams, minimising the risk of phytotoxicity.

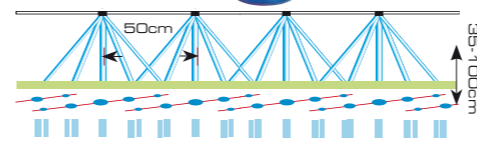

bar	1.5	2.0	2.5	3.0	4.0	5.0
ISO size/colour						
015-Green	0.42	0.49	0.55	0.60	0.69	0.77
02-Yellow	0.57	0.65	0.73	0.80	0.92	1.03
025-Lilac						
03-Blue	0.85	0.98	1.10	1.20	1.39	1.55
04-Red	1.13	1.31	1.46	1.60	1.85	2.07
05-Brown	1.41	1.63	1.83	2.00	2.31	2.58
06-Grey	1.70	1.96	2.19	2.40	2.77	3.10
08-White	2.26	2.61	2.92	3.20	3.70	4.13
10-Lt blue	2.83	3.27	3.65	4.00	4.62	5.16

### Nozzle size and application rate

ISO code & colour	15 Lt Green	10 Lt Blue	08 White	06 Grey	05 Brown	04 Red	03 Blue	025 Lilac	02 Yellow	015 Green	01 Orange	0075 Pink
bar	3.5	3.0	3.0	2.5	2.5	2.0	2.0	1.5	1.5	1.5	2.0	2.0
litres / min	6.48	4.90	4.32	3.65	3.27	2.76	2.25	1.83	1.57	1.38	1.11	0.94
litres per hectare at km/h	5	6	7	8	9	10	12	14	16	18	20	20
Standard Flat Fan		Syntal	Syntal	Syntal	Syntal	Syntal	Syntal	Syntal	Syntal	Syntal	Syntal	Syntal
LowDrift												
MINIDRIFT												
INJET			Syntal	Syntal	Syntal	Syntal	Syntal	Syntal	Syntal	Syntal	Syntal	Syntal
QUINTASTREAM	Syntal	Syntal	Syntal	Syntal	Syntal	Syntal	Syntal	Syntal	Syntal	Syntal	Syntal	Syntal

### Nozzle flow

km/h	L/ha															
	25.00	50.00	75.00	100.00	125.00	150.00	175.00	200.00	250.00	300.00	350.00	400.00	450.00	500.00	550.00	600.00
3				0.25	0.31	0.38	0.44	0.50	0.63	0.75	0.88	1.00	1.13	1.25	1.38	1.50
4			0.25	0.33	0.42	0.50	0.58	0.67	0.83	1.00	1.17	1.33	1.50	1.67	1.83	2.00
5		0.21	0.31	0.42	0.52	0.63	0.73	0.83	1.04	1.25	1.46	1.67	1.88	2.08	2.29	2.50
6		0.25	0.38	0.50	0.63	0.75	0.88	1.00	1.25	1.50	1.75	2.00	2.25	2.50	2.75	3.00
7		0.29	0.44	0.58	0.73	0.88	1.02	1.17	1.46	1.75	2.04	2.33	2.63	2.92	3.21	3.50
8		0.33	0.50	0.67	0.83	1.00	1.17	1.33	1.67	2.00	2.33	2.67	3.00	3.33	3.67	4.00
9		0.38	0.56	0.75	0.94	1.13	1.31	1.50	1.88	2.25	2.63	3.00	3.38	3.75	4.13	4.50
10	0.21	0.42	0.63	0.83	1.04	1.25	1.46	1.67	2.08	2.50	2.92	3.33	3.75	4.17	4.58	5.00
12	0.25	0.50	0.75	1.00	1.25	1.50	1.75	2.00	2.50	3.00	3.50	4.00	4.50	5.00		
14	0.29	0.58	0.88	1.17	1.46	1.75	2.04	2.33	2.92	3.50	4.08	4.67				
16	0.33	0.67	1.00	1.33	1.67	2.00	2.33	2.67	3.33	4.00	4.67					
18	0.38	0.75	1.13	1.50	1.88	2.25	2.63	3.00	3.75	4.50						
20	0.42	0.83	1.25	1.67	2.08	2.50	2.92	3.33	4.17	5.00						
22	0.46	0.92	1.38	1.83	2.29	2.75	3.21	3.67	4.58							
24	0.50	1.00	1.50	2.00	2.50	3.00	3.50	4.00	5.00							
26	0.54	1.08	1.63	2.17	2.71	3.25	3.79	4.33								
28	0.58	1.17	1.75	2.33	2.92	3.50	4.08	4.67								
30	0.63	1.25	1.88	2.50	3.13	3.75	4.38	5.00								
32	0.67	1.33	2.00	2.67	3.33	4.00	4.67									
34	0.71	1.42	2.13	2.83	3.54	4.25	4.96									
36	0.75	1.50	2.25	3.00												

If your water volume rate and spraying speed are known then use this table to identify the flow rate that will be required by the nozzle. The nozzle flow rate [litres/minute] selected from this table can then be used, together with the nozzle tables on the following pages, to identify a suitable nozzle





**Premium nozzles for precision applications**

New nozzles ensure a better distribution, so change nozzles every season to get best results. Choosing the right nozzle is a balance between the desired effect, wind drift and required work rate.

HARDI nozzles provide extended pressure range performance with spray qualities in 4 broad categories to deliver the best result.

HARDI nozzles can also be fitted on all sprayer brands!



**HARDI ISO Nozzles & Nozzle Caps**

Available with integrated SNAP-FIT cap or nozzle tip only:

Nozzles	Size:	0075	01	015	02	025	03	04	05	06	08	10	15	RRP inc GST
<b>F-110 Syntal</b>	1 piece	371963	371706	371707	371708	371946	371709	371710	371711	371712	371713	371966		\$4.83
	12 piece	750635	755643	755646	755649	750628	755652	755655	755658	755661	755664	750638		\$57.90
<b>F-110 Ceramic</b>	1 piece			371738	371739		371740	371741	371742	371743				\$7.65
	12 piece			755667	755670		755673	755676	755679	755682				\$91.83
<b>LD-110 Syntal</b>	1 piece		371817	371818	371819	371957	371820	371821	371893					\$8.61
	12 piece		755698	755699	755700	750632	755701	755702	755817					\$103.34
<b>LD-110 Ceramic</b>	1 piece		371822	371823	371824		371825	371826	371896					\$9.32
	12 piece		755703	755704	755705		755706	755707	755818					\$111.88
<b>MINIDRIFT Syntal</b>	1 piece			372111	372112	372113	372114	372115	372116					\$9.90
	6 piece			755840	755841	755842	755843	755844	755845					\$59.38
<b>Injet Syntal</b>	1 piece			371872	371873	371874	371875	371876						\$16.71
	6 piece			755801	755802	755803	755804	755805						\$100.24
<b>Quintastream Syntal</b>	1 piece			372002	372003		372004	372005	372006	372007	372008	372009	372010	\$17.42
	6 piece			750671	750672		750673	750674	750675	750676	750677	750678	750679	\$104.45
<b>F-01-80 Syntal</b>	1 piece		371931	371932	371933		371934							\$4.83
	12 piece		750640	750641	750642		750643							\$57.90

Nozzles & Caps	Size:	0075	01	015	02	025	03	04	05	06	08	10	15	RRP inc GST
<b>F-110 Syntal</b>	1 piece	371964	371764	371765	371766	371950	371767	371768	371769	371770	371771	371970		\$6.80
	12 piece	750634	755627	755628	755629	750626	755630	755631	755632	755633	755634	750636		\$81.46
<b>F-110 Ceramic</b>	1 piece			371772	371773		371774	371775	371776	371777				\$9.62
	12 piece			755635	755636		755637	755638	755639	755640				\$116.13
<b>LD-110 Syntal</b>	1 piece		371837	371838	371839	371958	371840	371841	371894					\$10.59
	12 piece		755708	755709	755710	750630	755711	755712	755815					\$127.51
<b>LD-110 Ceramic</b>	1 piece		371842	371843	371844		371845	371846	371897					\$11.29
	12 piece		755713	755714	755715		755716	755717	755816					\$135.48
<b>MINIDRIFT Syntal</b>	1 piece			372121	372122	372123	372124	372125	372126					\$11.86
	6 piece			755850	755851	755852	755853	755854	755855					\$71.21
<b>Injet Syntal</b>	6 piece			750344	750345	750346	750347	750348						\$112.10
<b>Quintastream Syntal</b>	1 piece			372011	372012		372013	372014	372015	372016	372017	372018	372019	\$19.38
	6 piece			750680	750681		750682	750683	750684	750685	750686	750687	750688	\$117.27

**Cone Nozzle 1553**

	Size:	1553-08	1553-10	1553-12	1553-14	1553-16	1553-18	1553-20	1553-22	1553-24	1553-30	1553-35	1553-40	RRP
	1 piece	370016	370027	370031	370042	370053	370064	370075	370086	370097	370101	370112	370123	\$3.21
	12 piece	750256	755031	755382	755064	755385	755097	755097	755066	755123	750257	755067	755068	\$38.56

**Swirl Plate 1554 for 1553 Cone Nozzle**

Colour:	Grey	Black	Blue	White		
	1 piece	370134	370145	370156	370167	\$1.94
	12 piece	755156	755158	755182	755157	\$23.13

**Cone Nozzle 1099**

Size:	1099-08	1099-10	1099-12	1099-15	1099-18	1099-20	1099-23	
1 piece	371309	371310	371311	371312	371313	371314	371315	\$8.36

**Cone nozzle 1299**

Colour:	White	Lilac	Brown	Yellow	Orange	Red	Green	Blue		
	1 piece	371507	371508	371509	371510	371511	371512	371513	371514	\$10.28

**Off centre nozzle**

size	1850 series					1740 series					G - Series			
	G 150	G 200	G 250	G 300	G 350	G 400	G 500	G 600	G 700	G 800	G 1000	G 1200	G 1600	
<b>3/8</b>	370366	370377	370381	370392	370403	370414								\$13.43
<b>1/2</b>							370425	370436	370447	370451				\$16.01
<b>1"</b>											371556	371557	371558	\$41.12

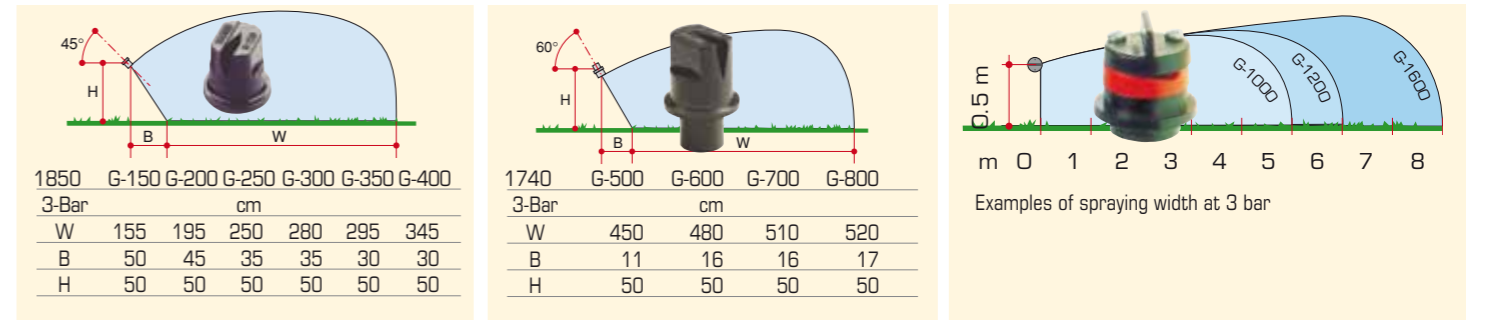

**HARDI Academy Profit through knowledge**



What is HARDI Academy? It is a training centre in Adelaide which is used to deliver the knowledge and the knowhow to get the best out of HARDI sprayers.

We aim to keep our customers spraying easier, faster and more efficiently and with the right training ensure their HARDI experience is beyond expectation.

The HARDI Academy makes available courses though out the year for customers, industry, dealers and students and is generally targeted to the different product groups and or market sectors. Courses can be product, application, technical or service orientated. We welcome farmer trips that include factory tours and dedicated training requirements.

If you are interested in participating in a HARDI Academy training course please email [academy@hardi-aus.com](mailto:academy@hardi-aus.com) with the product type you are using or the industry you are involved in.

# Dealer contacts

<b>New South Wales</b>		
Albury	Hartwigs Truck Pty Ltd	(02) 6049-6000
Armidale	Richardson Hardware & Agriculture	(02) 6772-7099
Ballina	Barlows Of Ballina	(02) 6686-2044
Bathurst	Sid Newham Rural Supplies	(02) 6331-1144
Bega	Plumb Motors	(02) 6492-1977
Blayney	Hill And Crofts	(02) 6368-2121
Bomaderry	Nowra Truck & Tractor	(02) 4422-5304
Boorowa.	Boorowa Pastoral Supplies	(02) 6385 3611
Bowral	Agriquip Machinery Co.	(02) 4861-1377
Box Hill	Rouse Hill Irrigation Equipment	(02) 9627 9292
Braidwood	Landmark	(02) 4842-2405
Camden	Southwell Agricultural	(02) 4655 7004
Casino	Days Machinery Centre	(02) 6662-1444
Castle Hill	A & L Irrigation	(02) 9659 9659
Coffs Harbour	Agrimow	(02) 6652-9893
Condobolin	Equipment & Service Co. Pty. Ltd.	(02) 6895-4222
Coolah	Haynes Farm Supplies	(02) 6377-1342
Cooma	Elders Limited	(02) 6452-1000
Coonabarabran	Newton's Mechanical Repairs	(02) 6842-1167
Coonamble	Chesterfield Australia-Coonamble	(02) 6822-5111
Cowra	Carruthers Machinery Co. (Cowra)	(02) 6342-4488
Crookwell	Nicholson Farm Machinery	(02) 4832-1073
Deniliquin	Combined Agricultural Machinery Pty Ltd	(03) 5881-1355
Denman	Denman Dakpos	(02) 6547-2204
Dorrigo	Stan Cork Machinery	(02) 6657-2588
Dubbo	Sprayer Barn	(02) 6882 0313
Dunedoo	Sullivan CRT	(02) 6375-1209
Finley	Armstrong Finley Sales & Service	(03) 5883-1655
Forbes	R.McClintock & Co.Forbes	(02) 6852-1200
Glen Innes	Sharmans Machinery	(02) 6732-3079
Gloucester	Gloucester Machinery Co P/L	(02) 6558-1510
Gosford	Gosford Irrigation & Pumping Supplies	(02) 4323-3999
Goulburn	Ranger Geale	(02) 4821-4266
Griffith	Serafin Spray Centre	(02) 6964-4777
Gunnedah	NFS Agribusiness	(02) 6742-7771
Guyra	Richardson Hardware & Agriculture	(02) 6779-2022
Hay	Lugsdin Toyota	(02) 6993-1661
Inverell	Inverell Power Farm Co Pty Ltd	(02) 6722-3388
Kempsey	Kempsey Produce & Saddlery	(02) 65623969
Lavington	Hartwigs Truck Pty Ltd	(02) 6049 6000
Leeton	Intersales	(02) 6953-3355
Lismore	Northern Rivers Machinery	(02) 6627-8450
Maclean	O'Halloran Motors Pty Ltd	(02) 6645-2844
Merriwa	Elders Limited	(02) 6548-2307
Moree	Geronimo Farm Equipment	(02) 6752-8388
Murwillumbah	Noel Graham Farm Machinery	(02) 6672-2555
Namibri	NVI - Namoi Valley Implements	(02) 6792-1988
Narromine	Landmark	(02) 6889-1177
Newcastle	SEMCO Equipment Sales	(02) 4954-7066
NewPort	Pittwater Mowers	(02) 9997-2755
North Manly	Pittwater Mowers	(02) 9939 6729

Oberon	Oberon Industrial & Farming Supplies	(02) 6336-1506
Orange	The Rural Centre Pty. Ltd.	(02) 6362-1899
Pennith	Agriturf	(02) 4721-4200
Quindi	North West Farm Machinery	(02) 6746-3300
Robertson	Murray Tractor Importers	(02) 4885-1209
Scone	Scone Rural Supplies	(02) 6545-1677
Singleton	Chapman & Slattery	(02) 6572-1112
Somersby	Central Coast Tractors	(02) 4372-1457
South Grafton	Leslie Farm & Garden Pty Ltd	(02) 6642 4127
St Marys	Semco Equipment Sales	(02) 9833-8000
Tamworth	Equipment & Service Co	(02) 6762-3000
Tamworth	Tamworth Co-Op Ltd	(02) 6765-4488
Taree	Sheathers Machinery	(02) 6557-7166
Temora	Intersales	(02) 6977-1933
Tenterfield	Col Mann Service Station	(02) 6736-1566
Terreyhills	Pittwater Mowers	(02) 9986-1226
Trangie	Joe Jones & Sons	(02) 6888-7122
Wagga Wagga	Hartwigs Truck Pty Ltd	(02) 6937-8500
Walcha	Richardson Hardware & Agricultural Hardware	(02) 6777-2699
Walgett	Walgett Truck & Tractor	(02) 6828-1991
Walla Walla	C.J. & L.H. Wiesner Pty Ltd	(02) 6029-2151
Warialda	McGregors Agricultural Services	(02) 6729-010
Warren	Chesterfield Australia-Warren	(02) 6847-3522
Wauchope	Sheathers Machinery	(02) 6585-3100
Wellington	Chesterfield	(02) 6845-1666
West Wyalong	R.McClintock & Co Pty Ltd	(02) 6972-2288
Windsor	Windsor Farm Equipment	(02) 4577-3613
Wingham	Sheathers Machinery	(02) 6553-4507
Young	South West Tractors	(02) 6382-3355

## Northern Territory

Katherine	BC Machinery	(08) 8972-1988
Winnellie	Vanderfield Pty Ltd	(08) 8932-4200

## Queensland

Atherton	Tableland Pumps & Pipes	(07) 4091-2277
Ayr	Furlongs Pumps & Sprayers	(07) 4783-1939
Beaudesert	Dover & Sons	(07) 5541-1977
Beerwah	Coochin Creek Fruitgrowers Co-Op	(07) 5494-6219
Biggenden	Biggenden Hardware & Rural Supplies	(07) 4127 1458
Biloela	Centracks Machinery	(07) 4992-1800
Boonah	Dover & Sons	(07) 5463-1388
Bowen	Centracks Bowen	(07) 4786-3044
Brendale	Chesterfield Australia	(07) 33252400
Bundaberg	Centracks Machinery	(07) 4152-2144
Caboolture	John Page Motors	(07) 5495-0555
Cairns	Nuleaf	(07) 4035 2670
Capalaba	Qturf Machinery Pty Ltd	(07) 3245-6082
Charters Towers	K&J Adevilles Pumps	(07) 4787 1549
Chinchilla	Vanderfield Machinery Pty Ltd	(07) 4662-7006
Currajong	Advanced Irrigation	(07) 4779-2677
Dalby	Sunstate Ag	(07) 4672-3333
Emerald	Centracks Machinery	(07) 4982-1556
Emerald	Central Bikes Centre	(07) 4982-1096

Gatton	Vanderfield Pty Ltd	(07) 5462-2566
Goondiwindi	Specialised Farm Machinery	07 46711088
Gympie	D & S Machinery	(07) 5482-1699
Hillcrest	Total Water Services	(07) 3800 3177
Ingham	The Irrigators Pty Ltd	(07) 4776-3163
Innisfail	North Coast Machinery Pty Ltd	(07) 4061-3422
Innisfail	The Water Shed	(07) 4061-6177
Ipswich	Ipswich Town & Country	(07) 3281-3188
Kingaroy	Kingaroy Mchinery Centre	(07) 4162-1266
Mackay North	Centracks Machinery	(07) 4966 3300
Malanda	Malanda Rural Supplies	(07) 4096-5455
Mareeba	John Beattie & Son	(07) 4092-2036
Maryborough	Kingstons Rural Supplies	(07) 4121 6634
Millmerran	David Evans Group	(07) 4695-1299
Mossman	Mossman Agricultural Services	(07) 4098-2286
Munduberra	David Evans Group	(07) 4165-4366
Murgon	South Burnett Machinery Pty Ltd	(07) 4168-1411
Nerang	Hinterland Mowers Pty. Ltd.	(07) 5578-1999
Nerang	Kubtrac Equipment Sales	(07) 5596-0222
Onmiston	Elders Ltd	(07) 3286-1394
Port Douglas	Port Irrigation & Horticultural Supplies	(07) 4098 5863
Proserpine	Proserpine Machinery Service	(07) 4945-1388
Rockhampton	Centracks Machinery	(07) 4927-3222
Roma	Mounts Machinery Pty Ltd	(07) 4622-5444
Salisbury	McCracken Water Services	(07) 3275-1633
St. George	Vanderfield Pty Ltd	(07) 4625-3666
Stanthorpe	Landmark	(07) 4681-2255
Toowoomba	Sunstate Ag	(07) 4633-1150
Townsville	Advanced Irrigation	(07) 4779 2677
Tully	Landmark	(07) 4068-3900
Tully	Tully Motors	(07) 4043-9999
Wamuran	Wamuran Co-op Ltd	(07) 5496-6500
Warwick	David Evans Group	(07) 4661-2699
Yandina	D & S Machinery	(07) 5446-7866
Yatala	Chesterfield Australia	(07) 3287-3877
Yeppoon	Yeppoon District Co-Op Socy Pty.	(07) 4939-1592
Yatala	Chesterfield Australia	(07) 3287-3877
Yeppoon	Yeppoon District Co-Op Socy Pty.	(07) 4939-1592

## South Australia

Bordertown	Wise Farm Equipment	(08) 8752-0633
Clare	Cox Rural Northern Pty Ltd	(08) 8842-1631
Cleve	Ramsey Brothers	(08) 8628-2100
Crystal Brook	Rocky River Ag Services	(08) 8636-2772
Cummins	Landmark Cummins Ag	(08) 8676-2161
Gawler	Fentons Machinery	(08) 8522-1633
Jamestown	Caltowie Agencies/ Quality Rural	(08) 8664-1415
Kadina	G & J. East	(08) 8821 1188
Kapunda	Kapunda Hardware & Garden Centre	(08) 8566-2306
Karoonda	GJ Clarke & Co	(08) 8578-1030
Keith	Farmer Centre Pty Ltd	(08) 8755-3222
Kimba	Ramsey Brothers	(08) 8627-2371
Kingscote KI	Nepean Motors	(08) 8553-2162

# Dealer contacts

Lock	Lock Agricultural Services	(08) 8689-1124
Lyndoch	Lyndoch Motors	(08) 8524-4140
Maitland	J&D Southwood Pty Ltd	(08) 8832-2346
Meningie	Swan Farm Machinery	(08) 8575-1588
Millicent	Millicent Farm Supplies	(08) 8733-4966
Mt Gambier	Elders Gambier Farm Supplies	(08) 8725-6533
Mt Gambier	Russell Industries	(08) 8725 2022
Mypolonga	Mypolonga Traders	(08) 8535-4188
Naracoorte	Top Mark Machinery	(08) 8762-0955
Nildottie	Nildottie Machinery	(08) 8570-1072
Oakbank	Paech Motors	(08) 8388-4111
Pinnaroo	Park Motors	(08) 8577-8141
Pt Lincoln	Lincoln Rural Supplies	(08) 8682-2711
Renmark	Riverland Farm Machinery	(08) 8586-3688
Renmark	Murray River Machinery	(08) 8586-6155
Strathalbyn	G&J East Strathalbyn	(08) 8536-3733
Tanunda	BMS - Barossa Machinery Services	(08) 8563-2008
Wudinna	Ramsey Brothers	(08) 8680-2200
Yankalilla	FP Agriservices	(08) 8558-3033
Yorketown	YP Agri Services	(08) 8852-1636

## Tasmania

Burnie	Tasmania Farm Equipment	(03) 6431-3255
Devonport	Tasmania Farm Equipment	(03) 6424-1511
Hobart	Tasmania Farm Equipment	(03) 6263-6377
Launceston	Tasmania Farm Equipment	(03) 6340-2811
Smithton	Tasmania Farm Equipment	(03) 6452-1222

## Victoria

Bacchus Marsh	Bacchus Marsh Farm Supplies	(03) 5367-3066
Bairnsdale	Donalda Motor Service Pty Ltd	(03) 5152-3058
Ballarat	Hewitt & Whitty Pty Ltd	(03) 5336-1344
Bendigo	Elders	(03) 5448-3722
Carrum Downs	MD.Tractors & Machinery	(03) 9775-0905
Casterton	Dowfarm Machinery Pty Ltd	(03) 5581-1500
Charlton	Charlton Ag Supplies	(03) 5491-1611
Cobram	Cobram Farm Equipment Pty Ltd	(03) 5872-1722
Coburg	Australian Mower Supply	(03) 9354-6499
Colac West	Landpower Colac Pty Ltd	(03) 5231-6322
Corroyong	Mildren & Coysh Pty Ltd	(02) 6076-1151
Donald	Harbergers Farm Supplies Pty Ltd	(03) 5497-1144
Echuca	Echuca Cih Sales & Service Pty Ltd	(03) 5482-1733
Geelong	J.B.Scott Pty Ltd	(03) 5277-9186
Geelong	Williams & Jackson Pty Ltd	(03) 5278-7888
Gisbourne	Wallace Farm & Industrial Supplies	(03) 5428-4266
Hamilton	AJW Fraser Pty.Ltd	(03) 5572-1166
Heywood	Heywood Ag Sales & Service Pty Ltd	(03) 5527-2266
Horsham	Wimmera Mallee Ag	(03) 5382-6103
Jeparit	Pfeiffers Fuel & Rural Supplies	(03) 5397-2008
Kaniva	Landmark	(03) 5392-2501
Kerang	KJ'sOutdoor & Marine	(03) 5450-3130
Korumburra	Bostons Garage	(03) 5655 1522
Kyabram	Kyabram Motorcycles & Power Equipment	(03) 5852-2122
Lake Bolac	Claas Harvest Centre	(03) 5350-2133

Leitchville	A.T.& P. Fry	(03) 5456-7314
Leongatha	Gendore Tractors & Machinery P/L	(03) 5662-4044
Lilydale	Graham Shaw Tractors	(03) 9735-0899
Maffra	Donalda Motor Service P/L	(03) 5147-1744
Melton	Jon Kay Agricultural Services	(03) 9743-5644
Mildura	Haeusler Farm Supplies	(03) 5021-2213
Mornington	Mornington Mowers	(03) 5977-1488
Mortlake	Madsens Farm Machinery	(03) 5599-2079
Myrtleford	Gino Favaro & Son Pty Ltd	(03) 5752-1478
Nagambie	John Sanderson Machinery	(03) 5794-2276
New Gisborne	Wallace Farm & Industrial Supplies	(03) 5428-4266
Nth Geelong	J.B. Scott Pty Ltd	(03) 5277-9366
Robinvale	Haeusler Farm Supplies	(03) 5026-1644
Sale	Tulloch Jenkins Elders	(03) 5144-2900
Sea Lake	Haeusler Farm Supplies	(03) 5070-2005
Shepparton	Bertoli Farm Machinery	(03) 5821-3299
Sunshine	Western Farm Service P/L	(03) 9363-8100
Swan Hill	Hepburn Agri Centre	(03) 5033-2416
Tooradin	Gendore Tooradin Pty Ltd	(03) 5998-3216
Traralgon	Leviston Pumps	(03) 5174-1718
Walpeup	Poole & Jackson	(03) 5094-1347
Walwa	Country Tractors	(02) 6037 1255
Wangaratta	R W E Fraser & Co	(03) 5721-4098
Warracknabeal	Belle-Vue Trading	(03) 5394-1070
Warracknabeal	Robert Smith & Co	(03) 5398-1500
Warragul	TracMac's Landpower Centre P/L	(03) 5623-4475
Warrambol	Swayn & McCabe	(03) 5561-4777
Werribee	Spraycare Pty Ltd	0412 826 921
Werribee	Werribee South Farm Supplies	(03) 9742-1600

## Western Australia

Albany	Farmers Centre	(08) 9842-2676
Bibra Lake	Mirco Bros Machinery	(08) 9434-6011
Boyup Brook	Boyup Brook Farm Supplies	(08) 9765-1017
Brookton	Coote Motors	(08) 9642-1108
Broome	Total Eden Watering Systems	(08) 9192 8289
Bunbury	Ag-South	(08) 9726-0333
Bunbury	Western Ag Pty Ltd	(08) 9725-7011
Busselton	Nicholls Machinery	(08) 9752-1466
Carlisle	Agriparts & Repairs	(08) 9362-6811
Carnarvon	Carnarvon Growers Association	(08) 9941-8384



Enter a postcode or suburb name:

Product type:

Any  
Broadacre  
SPRITOR  
Mistblowers  
Linkage  
12 Volt  
Knapsacks

## Website directory

You can also visit our website, and click on the 'Dealer locator' icon pictured above. This will prompt a dialogue box pictured right. Enter your postcode and the product group you are interested in. Hit the 'locate' button for a list of the local HARDI dealers...

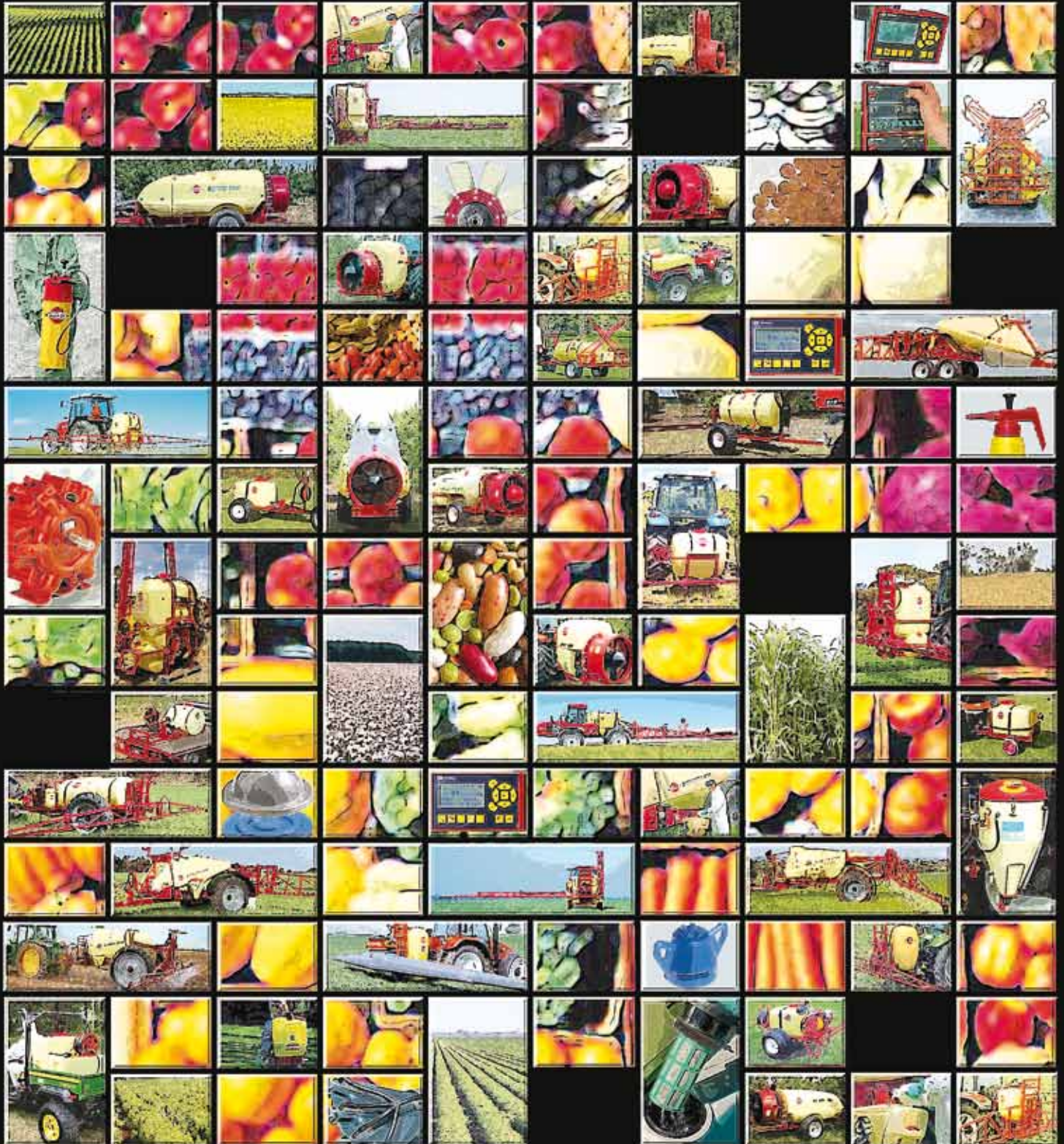

89000304 4-2010

**Your sprayer specialist**